

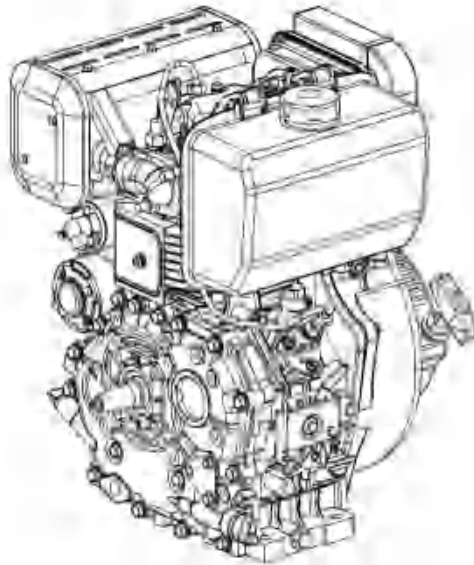

# 《RSAD Series Engine Maintenance Manual》

Please read this maintenance manual carefully before use.



- RSAD188 Series
- RSAD192 Series
- RSAD292 Series

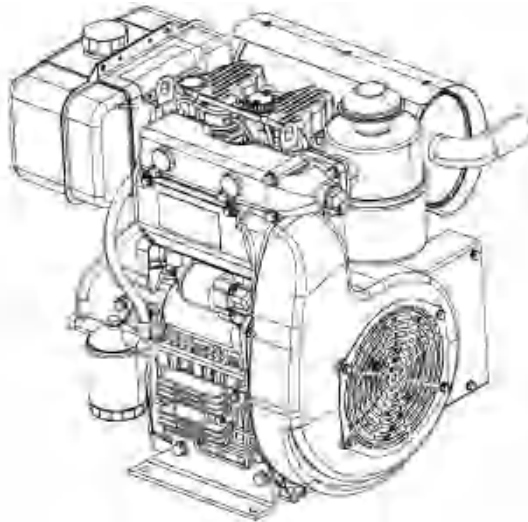

Raywin Powertrain Technology Co., Ltd.

2025.2

# **User Instructions**

This maintenance manual is intended to provide repair personnel with information on the construction, repair, and maintenance of the Raywin RSAD series of diesel engines.

To ensure the correct, rapid, and safe use and maintenance of the RSAD series diesel engines, please read this manual in detail. This manual is compiled based on the standard models, and when performing maintenance, please refer to the detailed instructions in the maintenance manual for the actual machine in use.

The main content of this manual includes product technical parameters, maintenance specification lists, maintenance and care, troubleshooting, tightening torques, inspections and adjustments, disassembly and assembly, as well as repairs. It provides explanations for operating steps, factory specifications, and allowable limits for each respective section.

All information, illustrations, and specifications mentioned in this manual are based on the latest product data.

**2025.2.27**

# I.The main technical specifications and parameters of a diesel engine

## (1)The main technical parameters of the RSAD series (variable speed) diesel engines

No.	Engine Model	RSAD188	RSAD192	RSAD292
1	Engine Type	Single cylinder, 4 stroke, Force Air cooled, vertical, DI	Single cylinder, 4 stroke, Force Air cooled, vertical, DI	2 cylinder, 4 stroke, Force Air cooled, vertical, DI
2	Bore×Stroke(mm)	88×75	92×75	92×75
3	Displacement (ml)	456	499	997
4	Compression ratio	19:1	19:1	20.5:1
5	Governor type	Mechanical variable speed	Mechanical variable speed	Mechanical variable speed
6	Rated power(kW)/(r/min)	6.8/3600	7.5/3600	15/3600
7	Max power(kW)/(r/min)	7.5/3600	8.2/3600	16.5/3600
8	Max torque(N.m)/(r/min)	21/2800	23/2800	50/2250
9	Idle speed(r/min)	1300±130	1300±130	1300±130
10	Lubricating system	Splash and pressure	Splash and pressure	Splash and pressure
11	Advance angle (°)	19±1	20±1	21±1
12	Start mode	Recoil manual start/Electrical start	Recoil manual start/Electrical start	Electrical start
13	Fuel tank capacity(L)	5.5	5.5	7.5
14	Air filter	paper filter	paper filter	Oil-bath type
15	Oil capacity(L)	1.65	1.65	2.8
16	Fuel consumption(g/kW.h)	280	270	270
17	Size (L×W×H) mm	420×440×495	420×440×495	420×480×590(not include fuel tank)
18	Net weight (kg)	47(Recoil Start) / 52(E-start)	50(Recoil Start) / 55(E-Start)	83(not include fuel tank)
19	Qty per container	180 units / 20ft	180 units / 20ft	108 units / 20ft

## (2) Main Technical Parameters of the RSAD Series (Constant Speed) Diesel Engines

No	Engine Model	RSAD188	RSAD192	RSAD292
1	Engine Type	Single cylinder, 4 stroke, Force Air cooled, vertical, DI	Single cylinder, 4 stroke, Force Air cooled, vertical, DI	2 cylinder, 4 stroke, Force Air cooled, vertical, DI
2	Bore×Stroke(mm)	88×75	92×75	92×75
3	Displacement (ml)	456	499	997
4	Compression ratio	19:1	19:1	20.5:1
5	Governor type	Mechanical fixed speed (G-drive)	Mechanical fixed speed( G-drive)	Mechanical fixed speed(G-drive)
6	Rated power(kW)/(r/min)	6.3/3000	7.5/3000	14/3000
7	Max power(kW)/(r/min)	6.8/3000	8.2/3000	15.5/3000
8	Idle speed(r/min)	1300±130	1300±130	1300±130
9	Lubricating system	Splash and pressure	Splash and pressure	Splash and pressure
10	Advance angle (°)	19±1	20±1	21±1
11	Start mode	Recoil manual start/Electrical start	Recoil manual start/Electrical start	Electrical start
12	Fuel tank capacity(L)	5.5	5.5	7.5
13	Air filter	paper filter	paper filter	Oil-bath type
14	Oil capacity(L)	1.65	1.65	2.8
15	Fuel consumption(g/kW.h)	275	260	260
16	Size (L×W×H) mm	420×440×495	420×440×495	420×480×590(not include fuel tank)
17	Net weight (kg)	47(Recoil Start) / 52(E-start)	50(Recoil Start) / 55(E-Start)	83(not include fuel tank)
18	Qty per container	180 units / 20ft	180 units / 20ft	108 units / 20ft

### (3) Specifications of Main Accessories

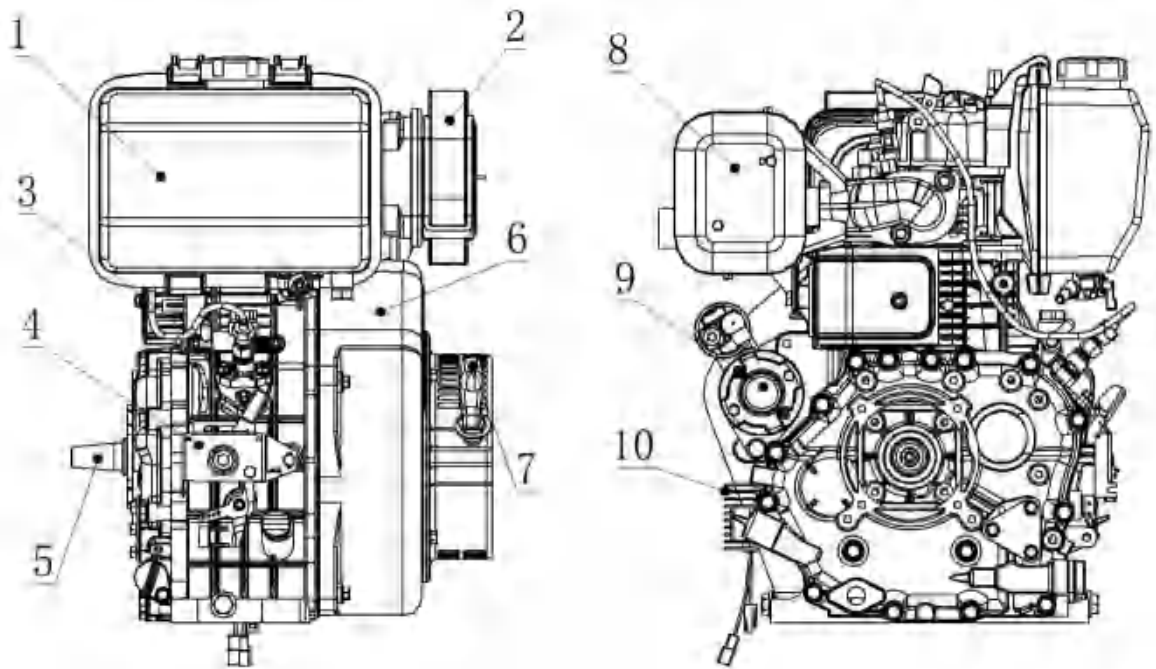

1.Fuel tank; 2.Air filter; 3.Injector; 4.Governor; 5.Output Shaft; 6.Air guiding shroud;  
7.Starting pull cord; 8.muffler; 9.Starter; 10.Regulator

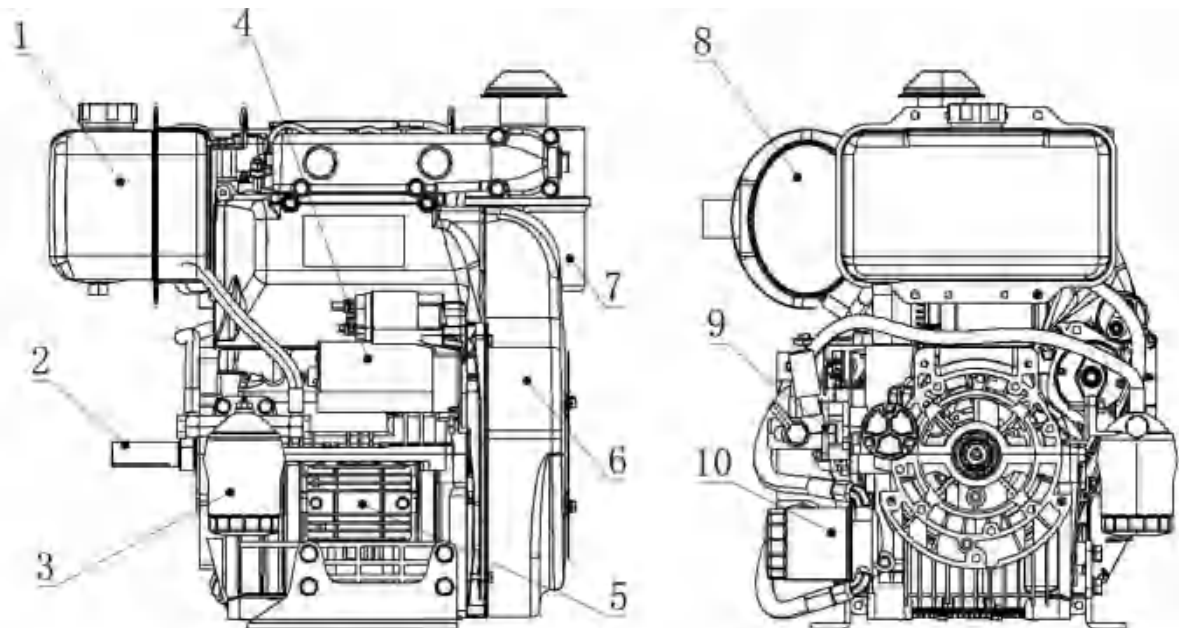







1.Fuel tank; 2.Output shaft(optional); 3.Fuel filter; 4.Starter; 5.Regulator(EU Standard);  
6.Air deflector shroud; 7.Air filter; 8.Muffler; 9.Fuel pump; 10.Oil filter



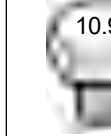
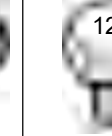

#### (4) Torque for Tighten Up Main Screw Bolt and Nut

Description	Model	RSAD188 series	RSAD192 series	RSAD292 series
	Connecting rod nut		40-45	40-45
Cylinder head nut		54-58	70-75	
Fly wheel nut		130-150	160-180	
Nozzle retainer		10-12	12-12	
Tight screw bolt of rocker support		20-22	20-22	
Standard M8 bolt		18-22	18-22	
Standard M6 bolt		10-12	10-12	

#### Table of tightening torques for standard screws (coarse thread)

Quality/ Dimensions	Resistance class (R)							
								
	R>400N/mm <sup>2</sup>		R>500N/mm <sup>2</sup>		R>600N/mm <sup>2</sup>	R>800N/mm <sup>2</sup>	R>1000N/mm <sup>2</sup>	R>1200N/mm <sup>2</sup>
Diameter	Nm	Nm	Nm	Nm	Nm	Nm	Nm	Nm
M3	0,5	0,7	0,6	0,9	1	1,4	1,9	2,3
M4	1,1	1,5	1,4	1,8	2,2	2,9	4,1	4,9
M5	2,3	3	2,8	3,8	4,5	6	8,5	10
M6	3,8	5	4,7	6,3	7,5	10	14	17
M8	9,4	13	12	16	19	25	35	41
M10	18	25	23	31	37	49	69	83
M12	32	43	40	54	65	86	120	145
M14	51	68	63	84	101	135	190	230
M16	79	105	98	131	158	210	295	355
M18	109	145	135	181	218	290	405	485
M20	154	205	193	256	308	410	580	690
M22	206	275	260	344	413	550	780	930
M24	266	355	333	444	533	710	1000	1200
M27	394	525	500	656	788	1050	1500	1800
M30	544	725	680	906	1088	1450	2000	2400

## Table of tightening torques for standard screws (fine thread)

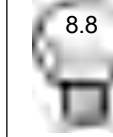
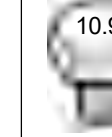
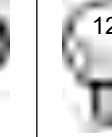
Resistance class (R)								
Quality/ Dimensions	 4.6	 4.8	 5.6	 5.8	 6.8	 8.8	 10.9	 12.9
Diameter	R>400N/mm <sup>2</sup>		R>500N/mm <sup>2</sup>		R>600N/mm <sup>2</sup>	R>800N/mm <sup>2</sup>	R>1000N/mm <sup>2</sup>	R>1200N/mm <sup>2</sup>
	Nm	Nm	Nm	Nm	Nm	Nm	Nm	Nm
M 8x1	10	14	13	17	20	27	38	45
M 10x1	21	28	26	35	42	56	79	95
M 10x1,25	20	26	24	33	39	52	73	88
M 12x1,25	36	48	45	59	71	95	135	160
M 12x1,5	38	45	42	56	68	90	125	150
M 14x1,5	56	75	70	94	113	150	210	250
M 16x1,5	84	113	105	141	169	225	315	380
M 18x1,5	122	163	153	203	244	325	460	550
M 18x2	117	157	147	196	235	313	440	530
M 20x1,5	173	230	213	288	345	460	640	770
M 20x2	164	218	204	273	327	436	615	740
M 22x1,5	229	305	287	381	458	610	860	1050
M 24x2	293	390	367	488	585	780	1100	1300
M 27x2	431	575	533	719	863	1150	1600	1950
M 30x2	600	800	750	1000	1200	1600	2250	2700

Couplings	Gap(mm)	Tolerance(mm)
Camshaft journal and housing in timing cover	0,017~0,047	0,1
Camshaft journal and housing in crankcase	0,015~0,048	0,1
End gap of compression rings	0,30~0,50	0,8
End gap of oil scraper rings	0,25~0,40	0,7
Connecting rod and wrist pin	0,023~0,038	0,07
Rockers and shaft	0,030~0,056	0,15
Main journals and bearings bushes	0,010~0,060	0,15
Oil pump drive gear spindle and housing in crankcase	0,030~0,065	0,115
External oil pump rotor and housing in engine crankcase	0,094~0,144	0,294
Pistons and wrist pin	0,002~0,008	0,05
Big end bearing and crank pin	0,020~0,072	0,17
Valve guide and stem: inlet	0,030~0,050	0,1
Valve guide and stem: exhaust	0,045~0,065	0,1

<b>Adjustments</b>	<b>MIN (mm)</b>	<b>MAX (mm)</b>
Valves	0,15	0,15
Valve depth from cylinder head	0,9~1,1	1,8
Dead space between cylinder face and piston	0,25	0,35
Protrusion of injector	2,25	2,75

<b>End floats</b>	<b>MIN (mm)</b>	<b>MAX (mm)</b>
Crankshaft	0,10	0,20
Camshaft	0,10	0,20
Oil pump shaft	0,01	0,05

# EXTRAORDINARY MAINTENANCE

AFTER THE FIRST  
50 WORKING HOURS

Engine oil replacement

Oil filter replacement

ORDINARY MAINTENANCE										
OPERATION DESCRIPTION			FREQUENCY x HOURS							
			10	125	250	500	1000	2500	5000	
CHECK	ENGINE OIL LEVEL									
	OIL BATH AIR CLEANER	(***)								
	DRY AIR CLEANER	(***)								
	FUEL PIPES									
	EXTERNAL ALTERNATOR BELT TENSION	(**)								
	COOLING SYSTEM CLEANING	(***)								
	VALVE-ROCKER ARMS CLEARANCE ADJUSTMENT									
	SETTING AND INJECTORS CLEANING									
	RUBBER INTAKE HOSE (DRY AIR CLEANER - INTAKE MANIFOLD)									
	FUEL TANK CLEANING									
	ALTERNATOR AND STARTING MOTOR									
REPLACEMENT	ENGINE OIL	(*)								
	EXTERNAL OIL FILTER	(*)								
	FUEL FILTER	(*)								
	EXTERNAL ALTERNATOR BELT									
	RUBBER INTAKE HOSE (DRY AIR CLEANER - INTAKE MANIFOLD)	(**)								
	FUEL PIPES	(**)								
	DRY AIR CLEANER EXTERNAL CARTRIDGE	(***)	AFTER 6 CHECKS WITH CLEANING							
	DRY AIR INTERNAL EXTERNAL CARTRIDGE	(***)	AFTER 3 CHECKS WITH CLEANING							
OVERHAUL	PARTIAL									
	TOTAL									

(\*) - In case of low use: every year.

(\*\*) - In case of low use: every 2 years.

(\*\*\*) - The period of time that must elapse before cleaning or replacing the filter element depends on the environment in which the engine operates. The air filter must be cleaned and replaced more frequently in very dusty conditions.

## II.Engine Assembly RSAD188/192 series assembly

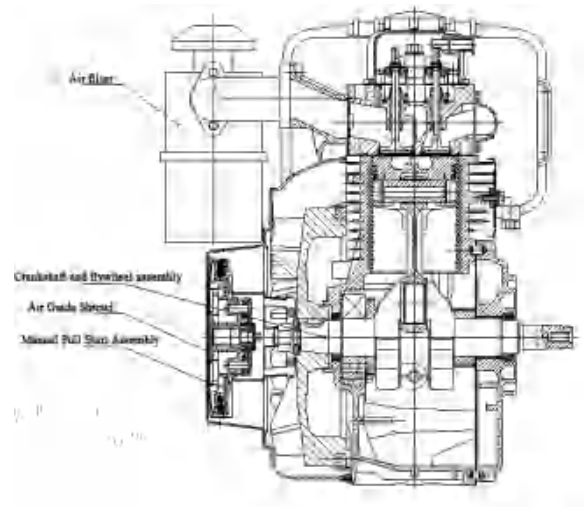
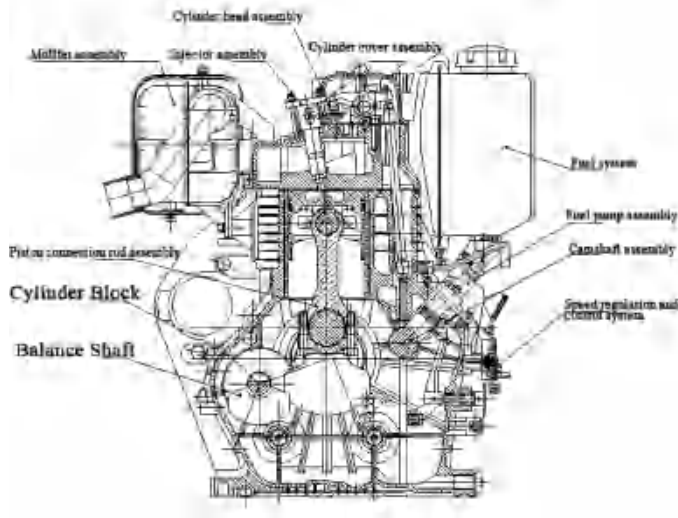

### 1.Crankcase

1.Press-fitting bearings 6202 and HK1512

2.Press-fitting bearing 081410 and oil seal

3.Install the lever shaft assembly and gasket

4..Install the oil drain plug and aluminum gasket

Install the vibration isolation strip for the air intake baffle, air intake baffle, vibration isolation sleeve for the air intake baffle, and bushing for the air intake baffle.

Install the fuel injection pump securing bolts (long and short)

Torque :9N-12N

Torque value:  
30N-35N

clearance of the speed-adjusting arm

Note: 1.The clearance between the speed-adjusting arm and the gearbox housing is 0.5mm-1mm, which can be adjusted by shims.  
2.Bolt torque value.

## 2.Crankshaft

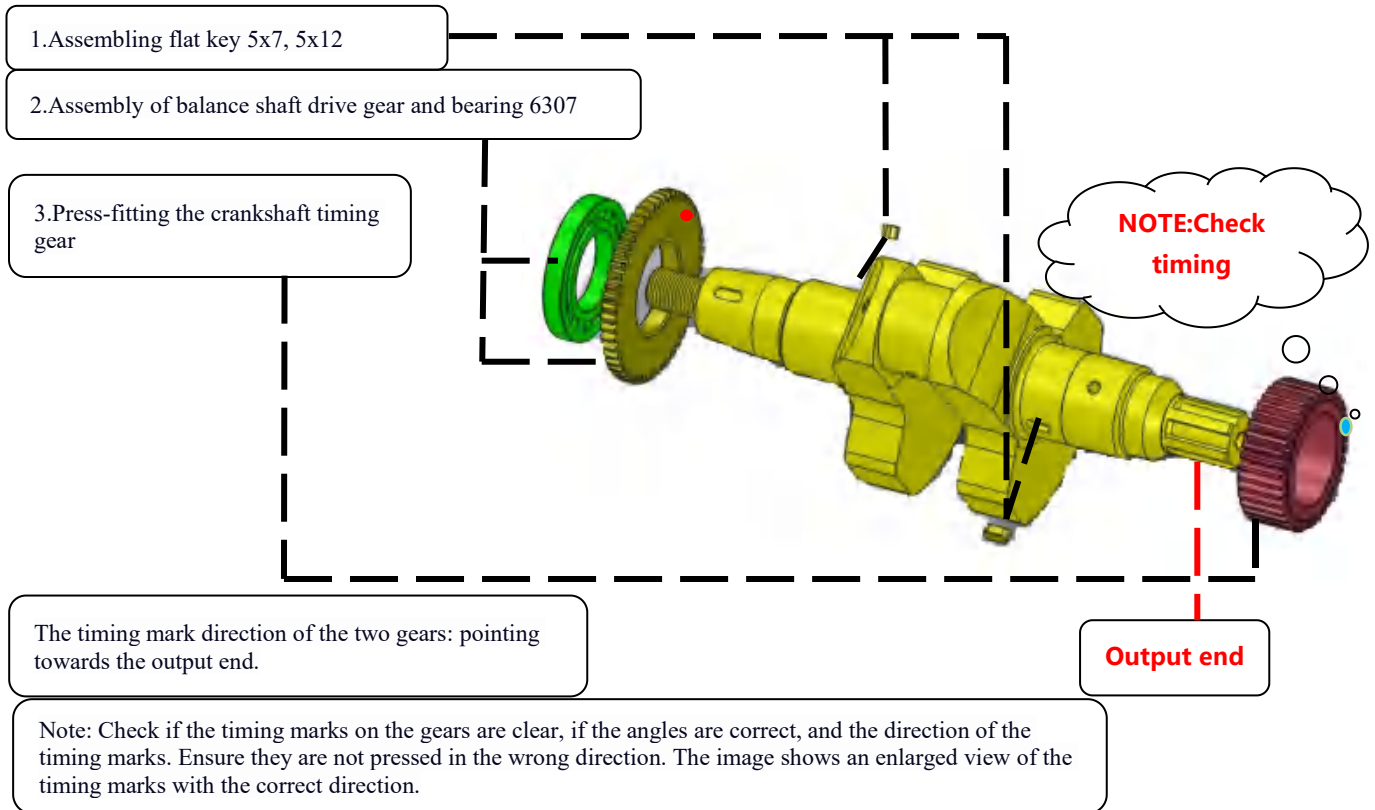

## 3.Balance shaft

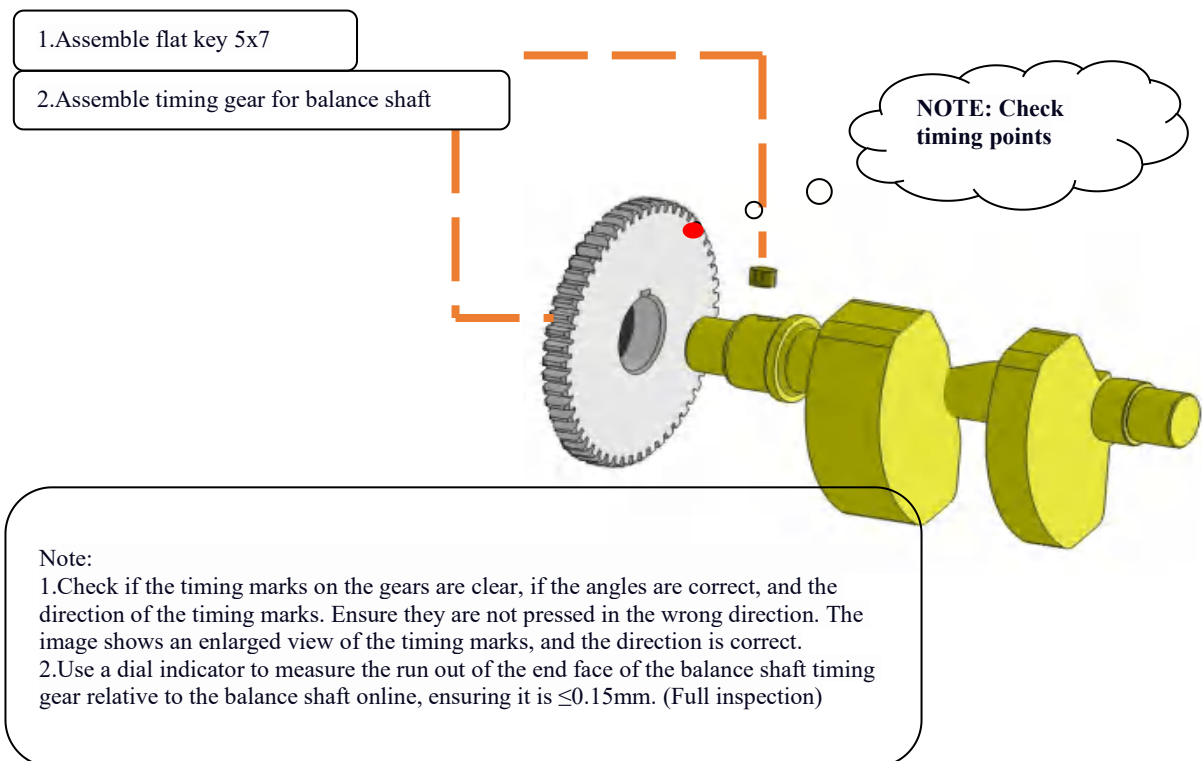

## 4. Crankshaft

1. Assemble flat key

2. Assemble camshaft timing gear

**NOTE: Check timing**

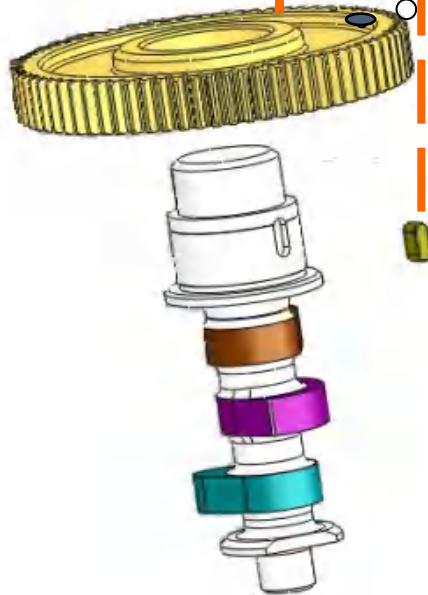

Note: Check if the timing marks on the gears are clear, if the angles are correct, and the direction of the timing marks. Ensure they are not installed upside down.

## 5. Cylinder head

Assemble valve guide oil seal

Turn the cylinder head over and assemble the intake and exhaust valves.

Flip it over again, assemble the spring washer, spring, spring seat, and locking clip, and then use a special tool to compress the locking clip.

Assemble the fuel injector studs, heat shield, heat shield washer, fuel injector, and fuel injector pressure plate. The torque value should be between 9N and 12N.

Assemble M6×60 studs, intake manifold gaskets, and M8×20 studs.

Note: After assembling the fuel injector, it is necessary to check the protrusion length of the fuel nozzle. As shown in the figure, use a measuring tool to verify that the protrusion length of the fuel nozzle is  $2.4\text{mm} \pm 0.1\text{mm}$ .



## 6. Gear Case

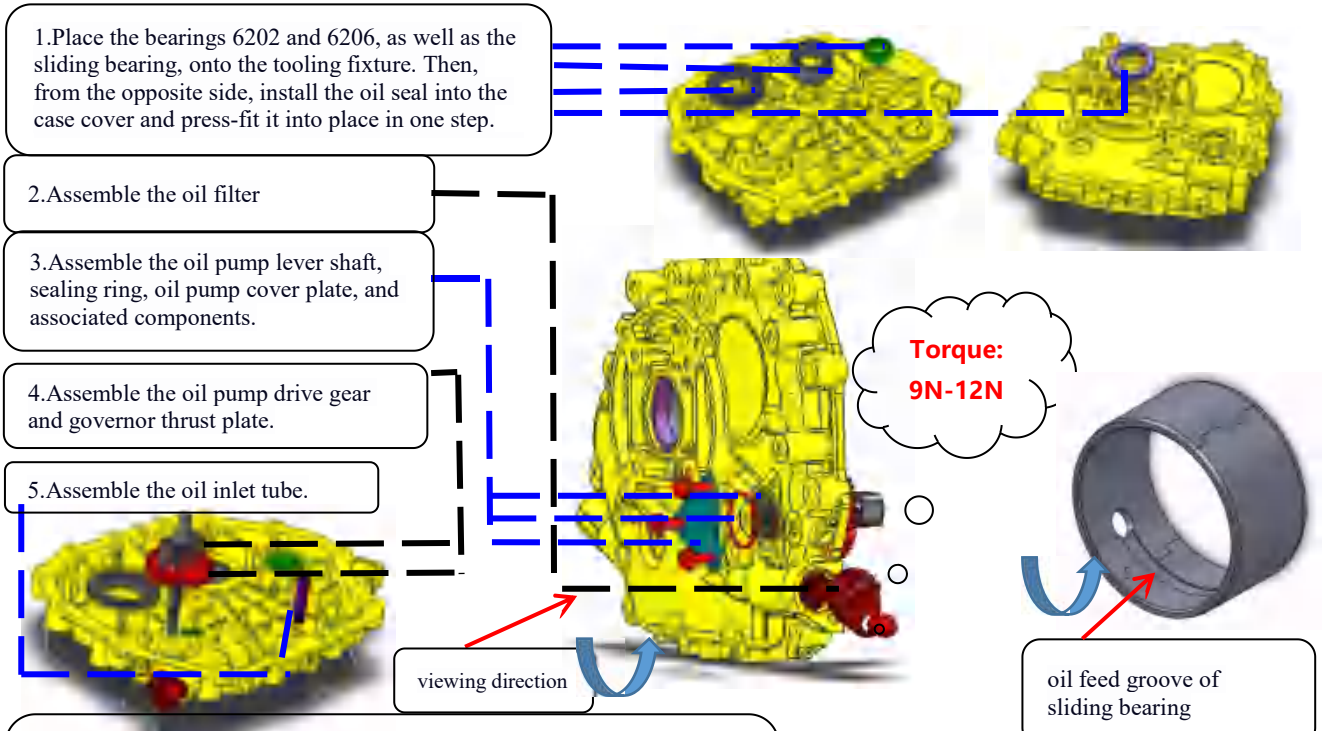

Note: When pressing and installing the sliding bearing, it is important to note that the oil feed groove should align with the rotation direction of the crankshaft. In the viewing direction of the above image, after startup, the crankshaft rotates counterclockwise. Therefore, when pressing and installing the sliding bearing, the oil feed groove should also be oriented

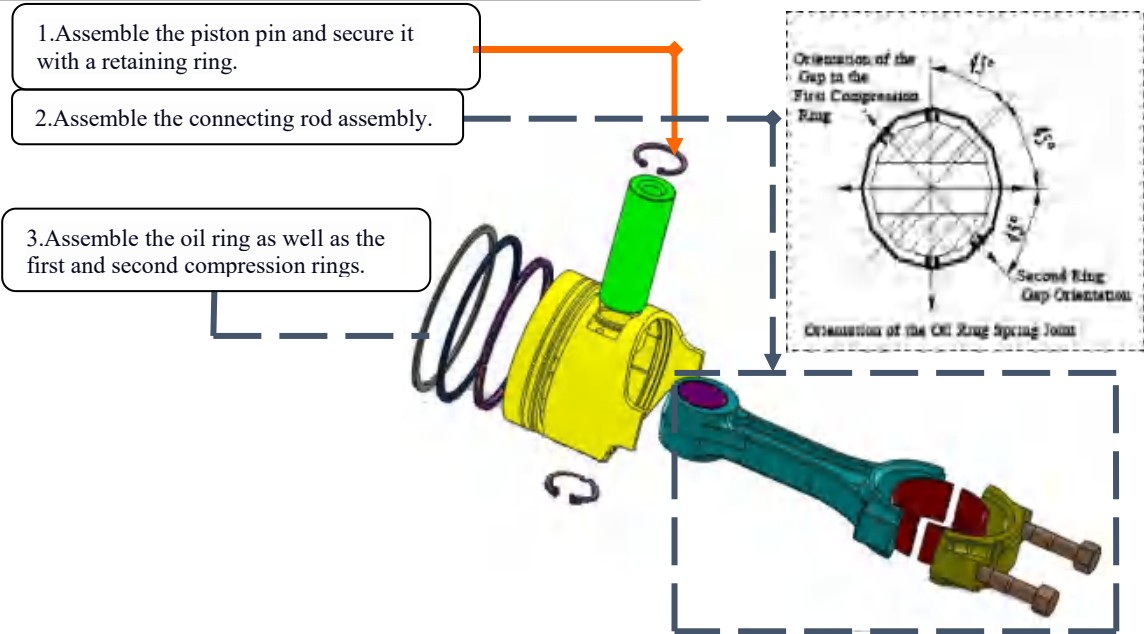

NOTE: Oil ring opening perpendicular to piston pin hole. Second ring staggered 45° from oil ring, first ring 150-180° from second. Oil ring's marked side faces up.

## 8. Air deflector shroud

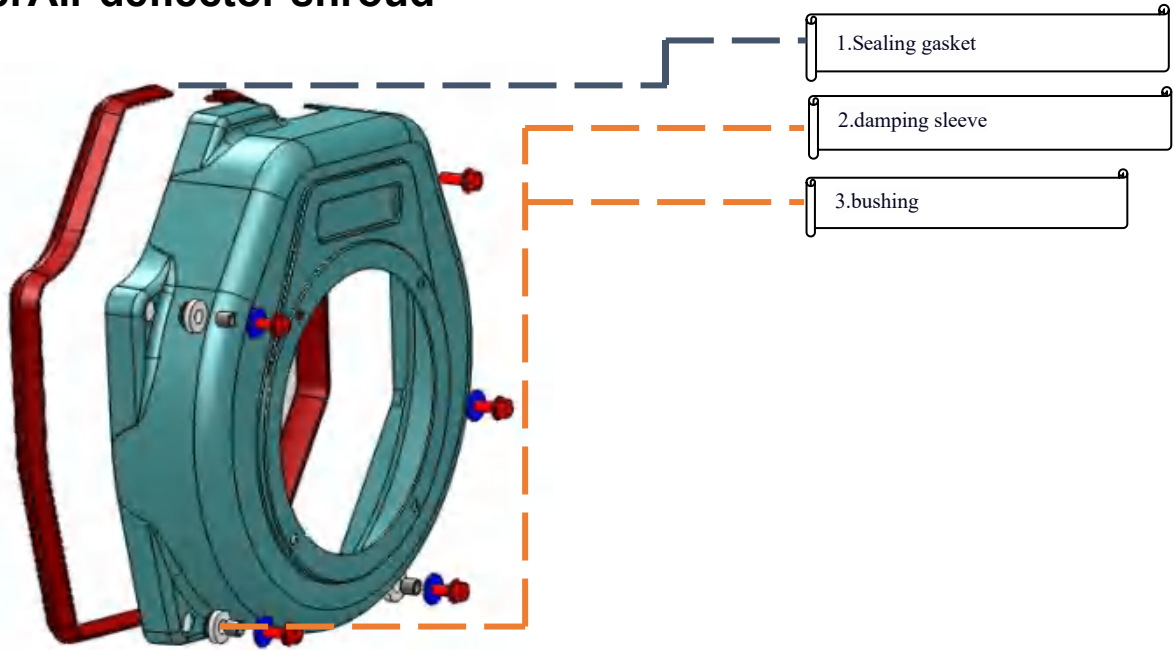

## 9. Fuel tank

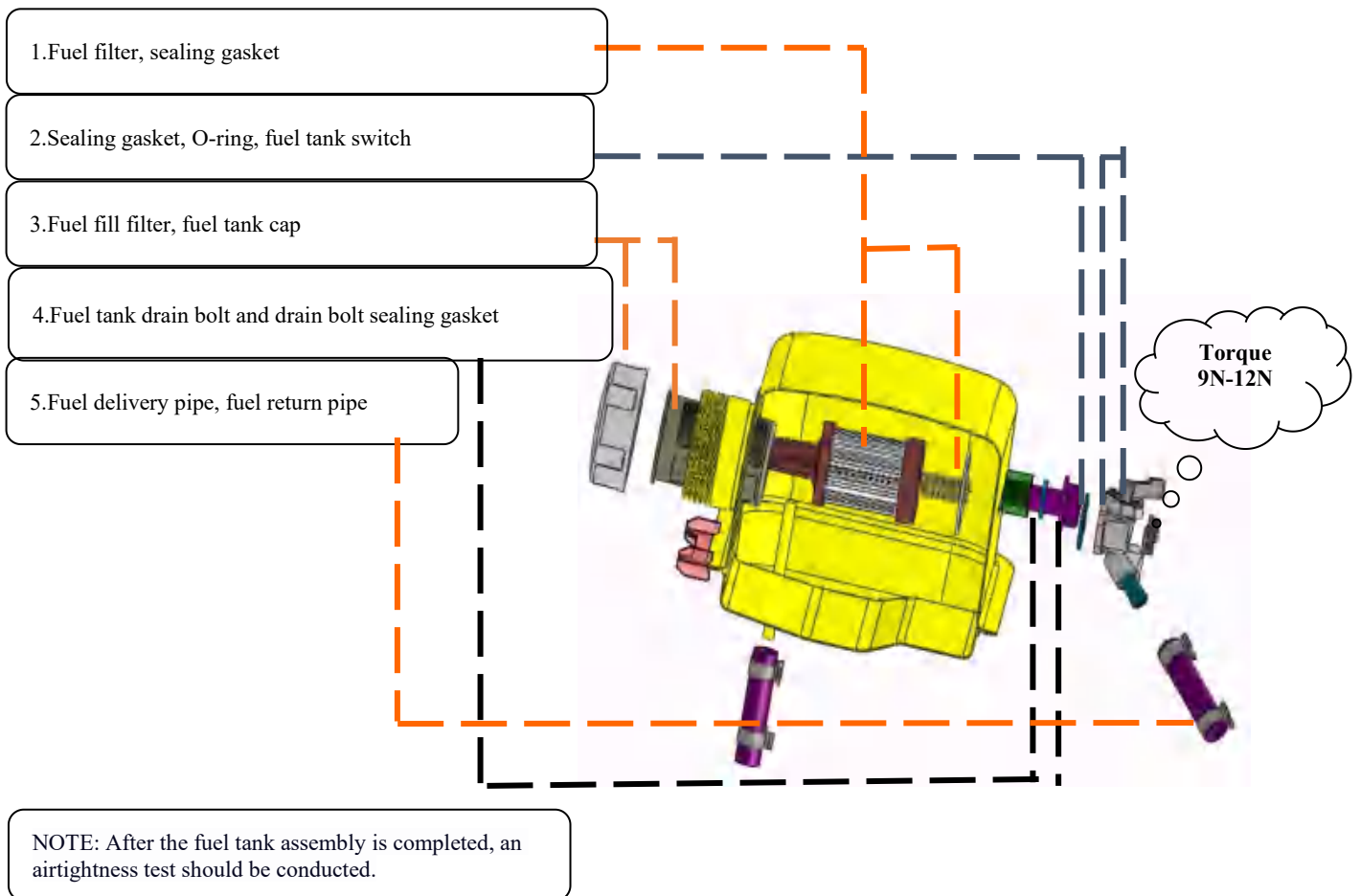

## 10. Piston

The piston and connecting rod are assembled from above.

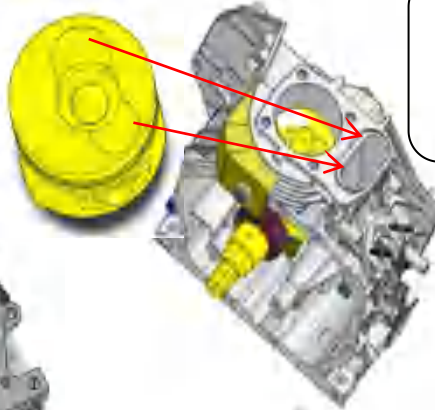
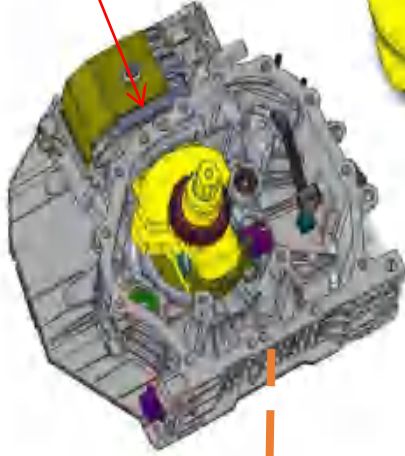

Before installing the piston, spray an appropriate amount of engine oil onto the cylinder liner wall using a spray bottle.

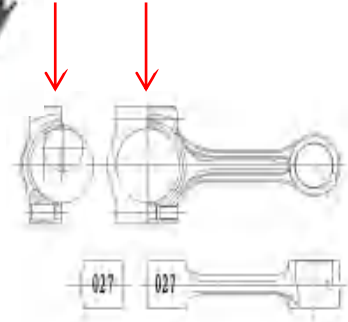

1. Assemble the connecting rod to the crankshaft and tighten it with the connecting rod bolt to a torque value of 30N~35N.
2. The two semicircular eccentricities on the upper surface of the piston point towards the rectangular groove.
3. Place the side with text on the connecting rod on one side.

## 11. Transmission mechanism

1. Assemble the balance shaft components first.

2. Then, assemble the valve tappets.

3. Finally, assemble the camshaft components.

Apply a small amount of engine oil to the tappet surface.

The timing mark indicates that the timing point on one gear aligns within the space between two marks on another gear.

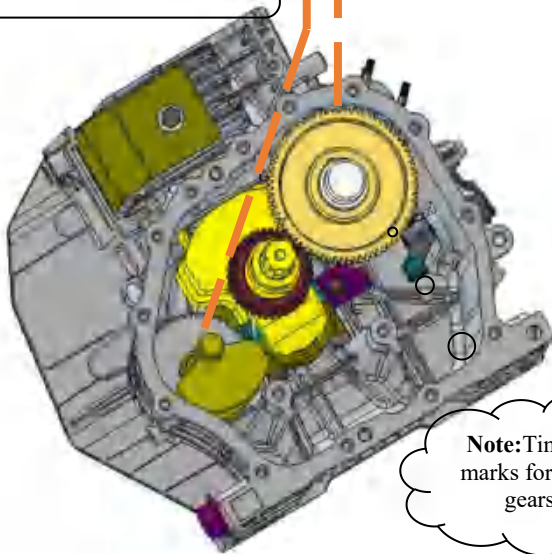

**Note:** Timing marks for four gears

## 12.Assemble case

1.Assemble the locating pin first.

2.Then, assemble the sealing gasket.

3.Apply an appropriate amount of sealant, model: Silicone Rubber Plane Sealant 587.

Finally, after assembling the cover, fasten it with bolts.

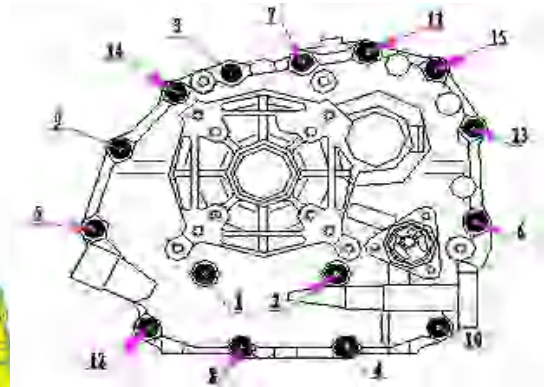
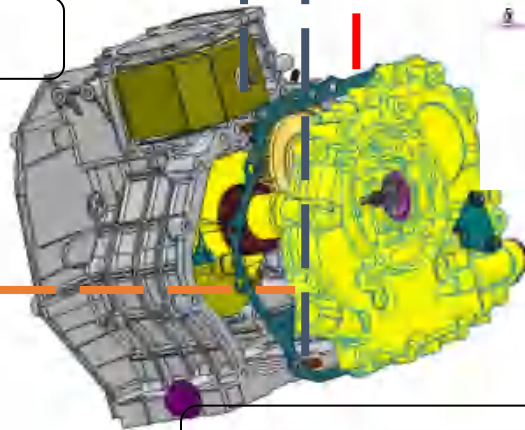

Note: Tighten the bolts in the order shown in the right figure with a torque value of 22N to 25N.

## 13.Flywheel

1.Assemble the flat key.

Inspect the taper of the flywheel.

Assemble the flywheel

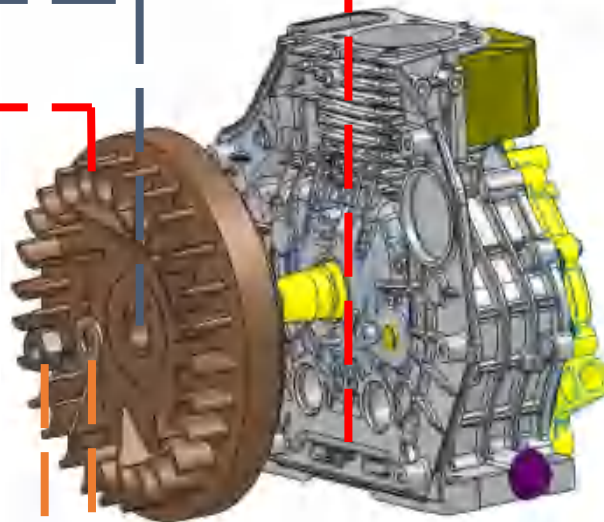

Lastly, assemble the gasket and nut. Apply a small amount of thread locking sealant 202 to the flywheel nut, then tighten it with a torque of 130N to 140N.

Re-check the torque of the nut. If it does not meet the requirements, take decisive action to stop further proceeding.

## 14. Measure piston clearance.

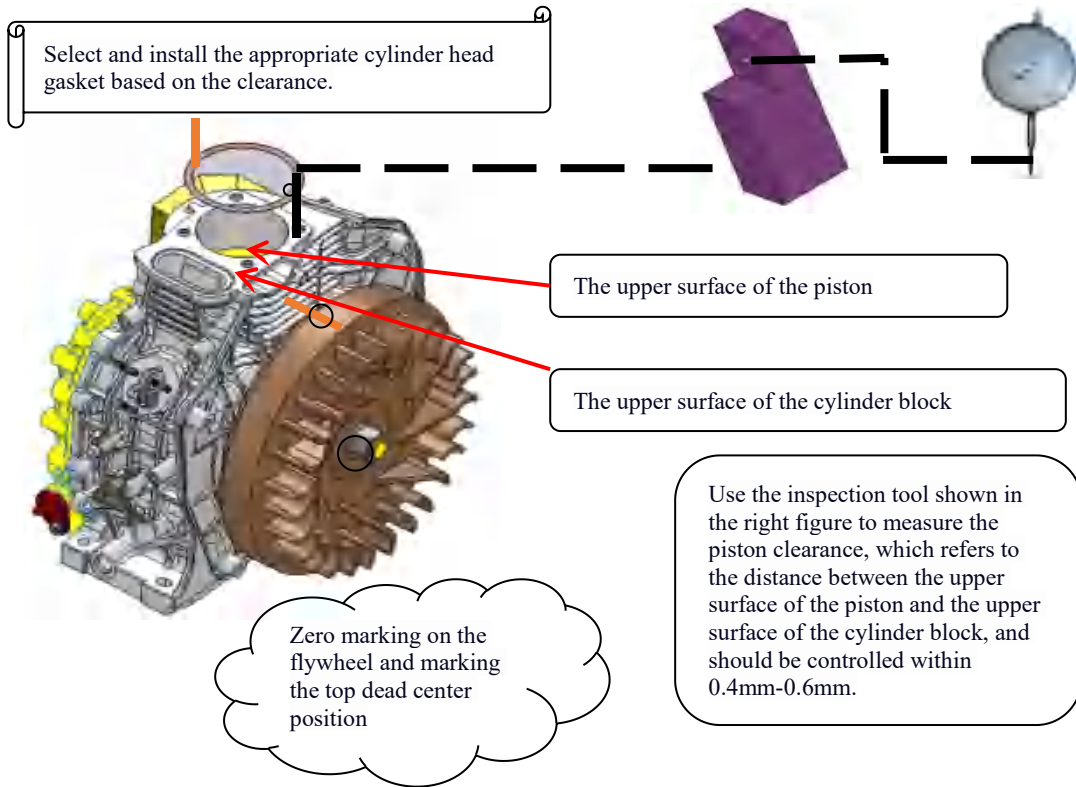

## 15. Fuel pump

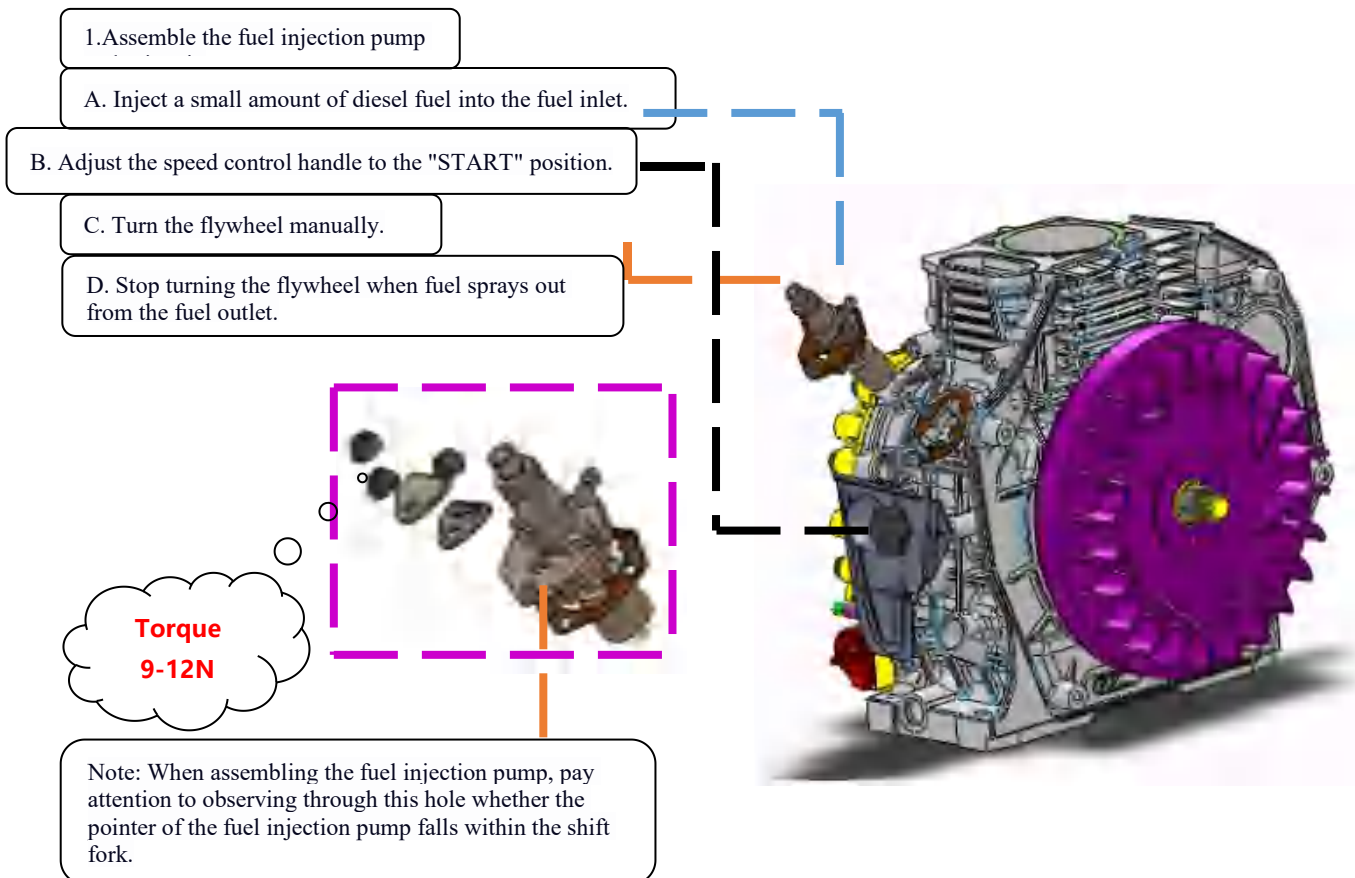

## 16. Cylinder head

1. Assembly cylinder head

First, assemble the cylinder head bolts (two short ones and two long ones).

Then place the rectangular sealing ring into the sealing groove.

Then insert the push rod into the rectangular

Finally, assemble the cylinder head and tighten it



**Nut torque:  
40N ~ 45N**

Bolt with accurate R end

Bolt with flat end

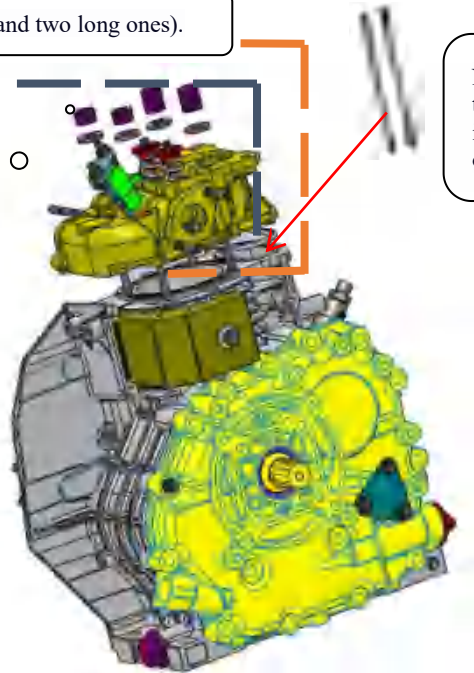

Note: The lower joint of the push rod should fit into the spherical groove of the tappet.

When assembling the cylinder head bolts, the flat end of the bolt should be installed downwards into the cylinder block, with the arcuate R end facing upwards.

## 17. Adjust the valve clearance.

Assemble the rocker arm and adjust the valve clearance:

First, assemble the valve adjustment shim.

Then, assemble the rocker arm.

**Torque  
35N ~ 40N**

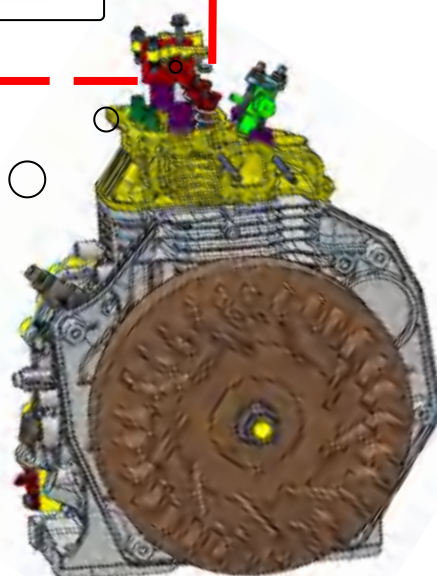

## 18. Cylinder head cover and manual starter

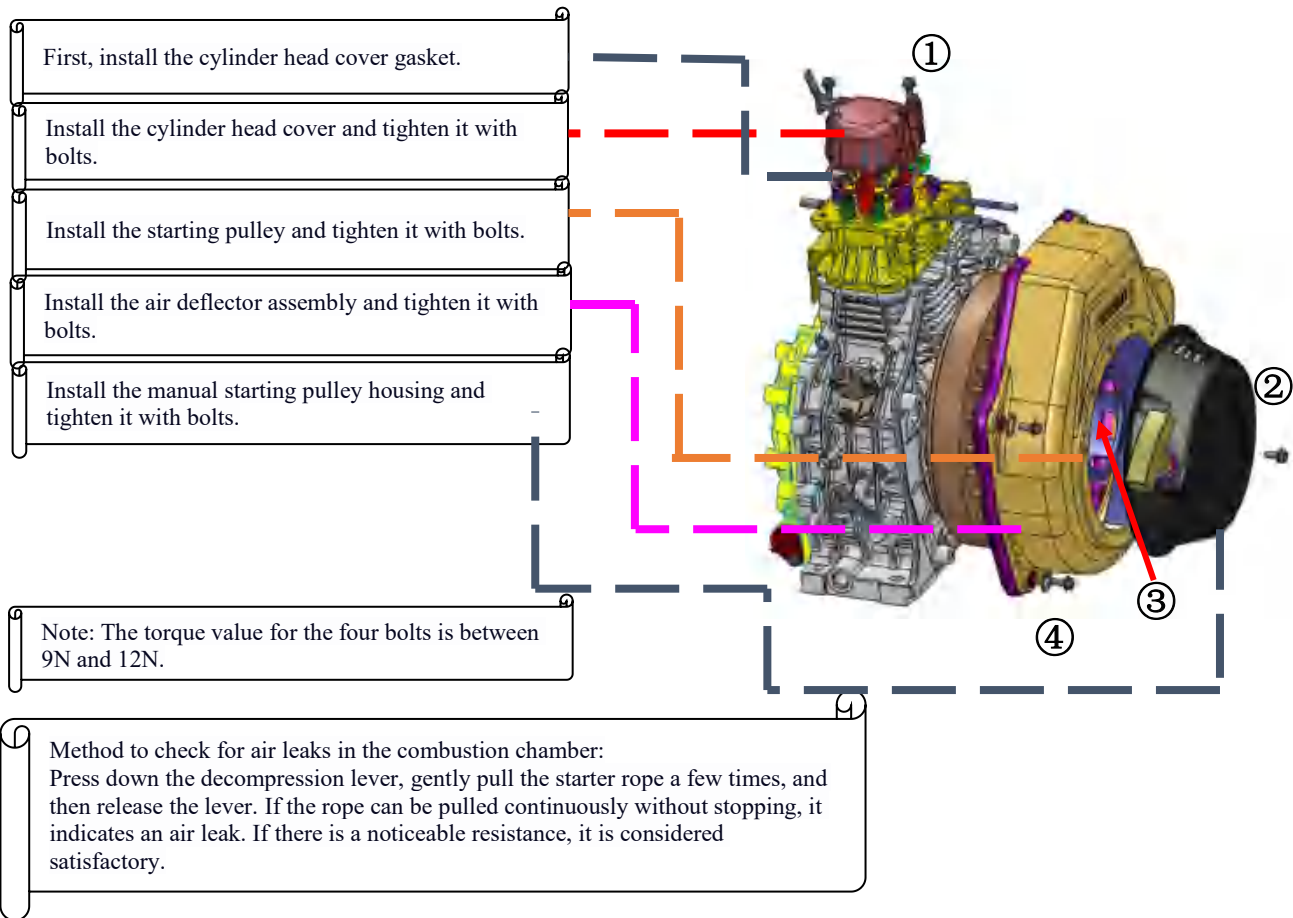

## 19. High pressure pipe & Fuel tank

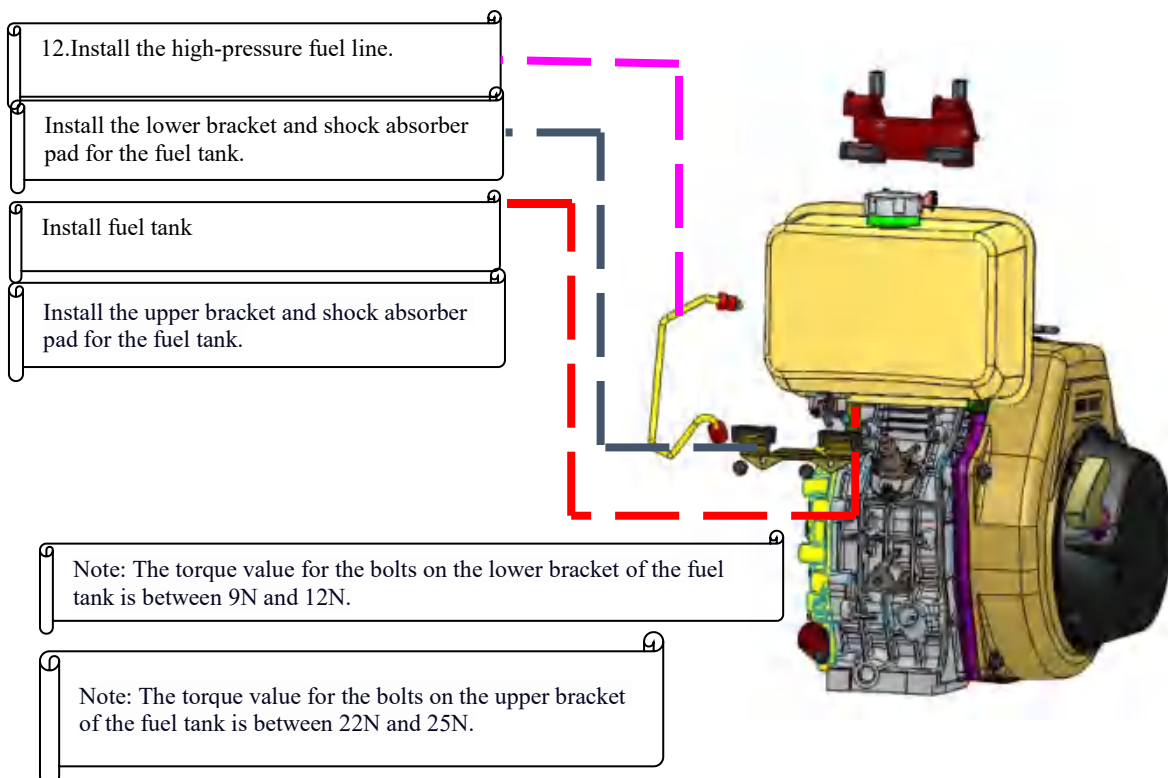

## 20.Muffler

Method: First, pre-tighten the lower end of the muffler using a flat washer (size 6), a spring washer (size 6), and an M6 bolt. Then, secure the upper end of the muffler with an M8 bolt, along with a flat washer (size 8) and a spring washer (size 8), applying a torque of 22N to 25N. Finally, tighten the lower end again, applying a torque of 9N to 12N.

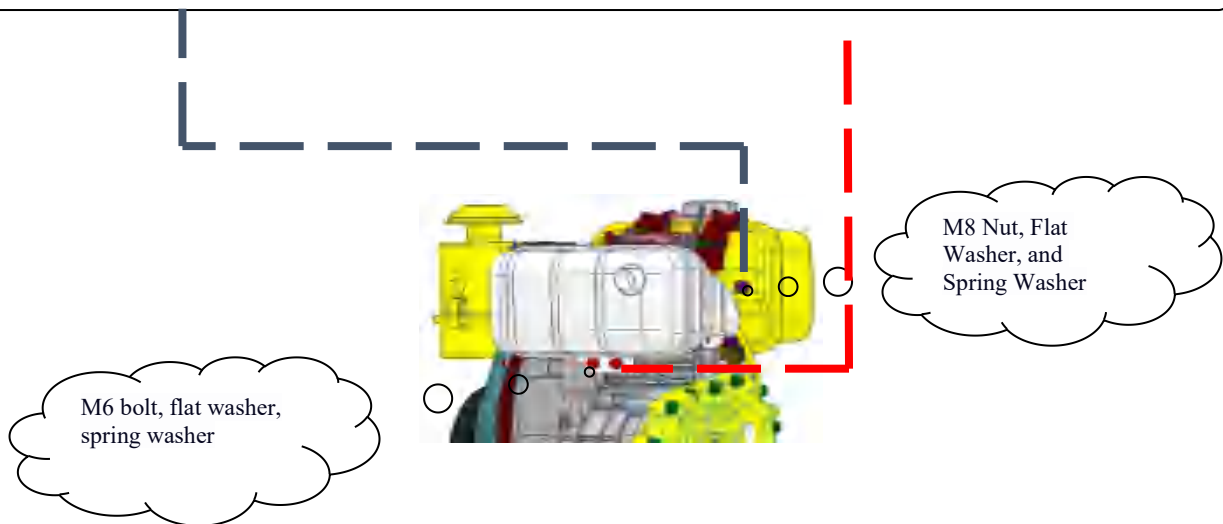

## 21.Air filter

Assembly air filter

Tighten the intake elbow using two M6x22 bolts with a torque value ranging from 9N to 12N.

Tighten the air cleaner holder using one M6x22 bolt with a torque value ranging from 9N to 12N.

After installing the gasket on the air cleaner holder, tighten the air cleaner using three M6 nuts with a torque value ranging from 9N to 12N.

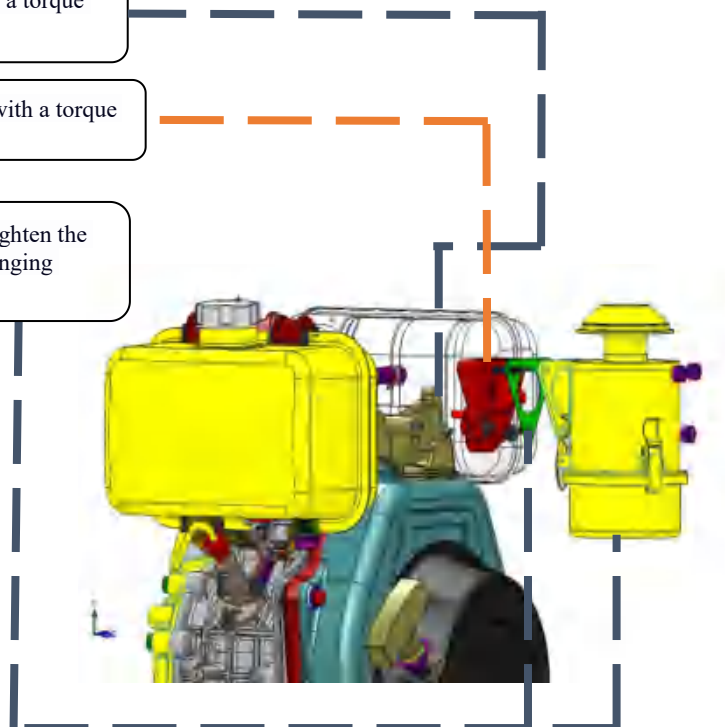

## Common faults and maintenance of single-cylinder diesel air-cooled engines

Difficulty in Starting or Inability to Start the Diesel Engine: Mainly Divided into  
a) Fuel System Malfunction; b) Poor Cylinder Compression System

Project	Disassemble or Inspect Parts	Disassembly Steps and Precautions	Tools
1	Check if the fuel switch is turned on.	Turn on the fuel switch	/
2	Check if there is air in the fuel delivery line or if it is blocked.	<ol style="list-style-type: none"> <li>① Use a needle-nose pliers to open the fuel line clamp, taking care not to tear or damage the fuel line.</li> <li>② Drain the fuel.</li> <li>③ Once the fuel flows smoothly, use the needle-nose pliers again to properly assemble the fuel line.</li> </ol>	needle-nose pliers

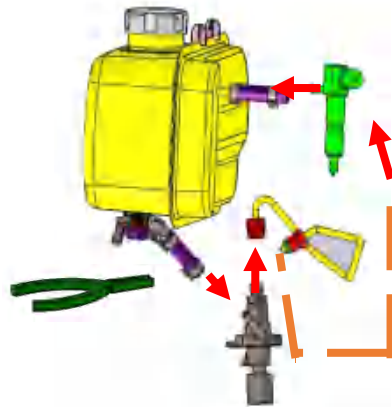

Project	Disassemble or Inspect Parts	Disassembly Steps and Precautions	Tools
3	Fuel injection pump clogging	<ol style="list-style-type: none"> <li>① Use a 17mm wrench to remove the high-pressure fuel line in a counterclockwise direction.</li> <li>② Press down the decompression handle and pull the starting puller. Stop after fuel is ejected. If no fuel is ejected, use a 6mm socket wrench to remove the fuel injection pump's fastening nuts in sequence.</li> <li>③ Clean the fuel injection pump with diesel. When assembling the fuel injection pump, note: First turn the handle to position the shift fork in the middle of the fuel injection pump hole, and confirm from the observation hole below the fuel injection pump that the pointer of the fuel injection pump falls within the speed control lever's shift fork.</li> </ol>	17mm wrench 6mm socket wrench

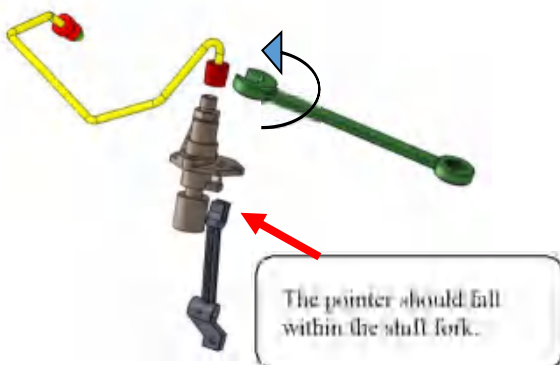

**NOTE:** Special attention should be paid during assembly at the user's location to avoid causing overspeed running.

Project	Disassemble or Inspect Parts	Disassembly Steps and Precautions	Tools
4	Injector clogging	<ol style="list-style-type: none"> <li>1.Remove the high-pressure fuel line at the injector end with a 17mm wrench, turning counterclockwise.</li> <li>2.Use a 6mm socket wrench to remove the nuts on the injector clamp.</li> <li>3.Gently lever the lower end of the injector with a flathead screwdriver to extract it. Be careful when removing to prevent the adjusting shim from being dislodged and falling into the cylinder head.</li> <li>4.Reinstall the injector into the high-pressure fuel line and pull the starter rope. Fuel will spray out in a mist from the injector's orifice.</li> </ol>	

The fuel is injected in a mist form.



Project	Disassemble or Inspect Parts	Disassembly Steps and Precautions	Tools
5	Return fuel line has air	Use needle-nose pliers to open the retaining ring, and reinstall it once the fuel flows smoothly. Note: Avoid damaging the fuel line.	needle-nose pliers
6	Fuel	The presence of water in fuel, prolonged unused fuel that has deteriorated, incorrect fuel grade, and other factors may all lead to difficulty in starting.	/
7	Fuel filter clogging	The fuel is dirty and contains impurities. Use a 6mm socket wrench to open the nut at the fuel tank switch and remove the fuel filter. Clean the filter with diesel. Note: There are two sealing gaskets and one O-ring; do not lose them.	needle-nose pliers 6mm socket wrench

NOTE: Do not lose the seals.

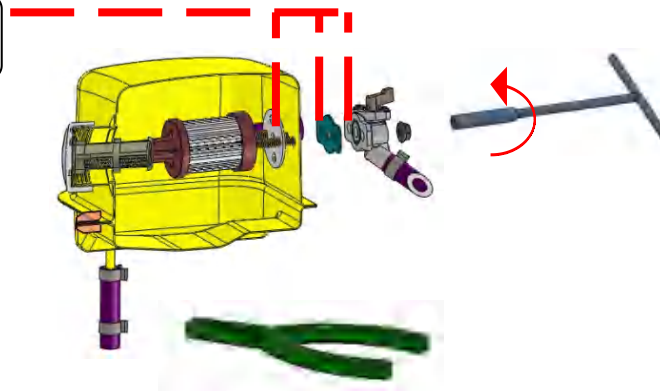

Project	Disassemble or Inspect Parts	Disassembly Steps and Precautions	Tools
B.Poor Cylinder Compression System			
1	Valve leakage	There is debris stuck between the intake and exhaust valves and their valve seats. Use a torque wrench with more than 55N of torque and a 14mm socket to loosen the cylinder head nuts. Then, use a tool to compress the valve springs and remove the debris.	14mm socket
2	Leakage at the joint surface of the cylinder head	1.Damage to the rectangular sealing ring 2.Fracture of the cylinder head gasket, requiring replacement of parts	17mm socket

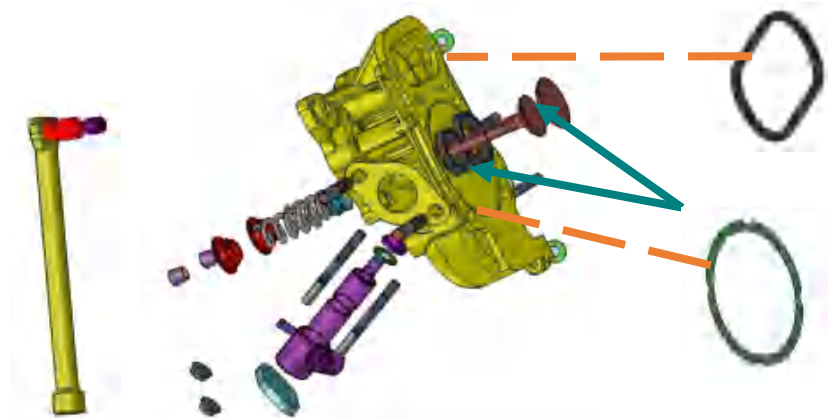

Project	Disassemble or Inspect Parts	Disassembly Steps and Precautions	Tools
3	piston rings are severely worn.	<p>If the above issues occur with the piston rings, they all require replacement. The disassembly steps are as follows:</p> <ol style="list-style-type: none"> <li>1.Use a 6mm socket wrench to remove the cylinder head cover.</li> <li>2.First, use a needle-nose pliers to remove the fuel tank oil pipe clamps at the upper and lower ends, and then use a 12mm socket to remove the fuel tank upper bracket fastening bolts.</li> <li>3.Use a 6mm socket wrench to remove the two bolts at the lower end of the muffler.</li> <li>4.Use a torque wrench with a 14mm socket to remove the cylinder head, leaving the air filter and muffler on the cylinder head.</li> <li>5.Use a torque wrench with a 12mm socket to remove the crankcase cover.</li> <li>6.Use a torque wrench with a 13mm socket to remove the connecting rod bolts.</li> <li>7.Use a rubber tool to push the piston out of the cylinder liner.</li> <li>8.Remove the piston rings.</li> </ol>	6mm Socket Wrench Torque Wrench 14mm Socket 12mm Socket 13mm Socket Needle-nose Pliers
4	Piston broken		
5	Piston rings are cemented together		

During the repair process, priority should be given to troubleshooting fuel system issues and leaks at the joint surface of the cylinder head, with piston ring issues considered last. So far, similar problems with piston rings have not been identified.

II. Insufficient Power in Diesel Engines: a) Faults in the Fuel System b) Faults in the Intake and Exhaust System  
c) Poor Cylinder Compression.

Project	Disassemble or Inspect Parts	Disassembly Steps and Precautions	Tools
a. Fuel system fault			
1	Fuel line clogging	Regarding insufficient power, for the fuel system, the main manifestations are blocked oil passages and insufficient fuel supply. Potential components that may become clogged include the fuel tank valve, fuel injector, and fuel injection pump. Refer to Part One: Difficulty in Starting Diesel Engines \ Fuel System Faults for the disassembly method. For the disassembly of the fuel tank valve: Use a 6mm socket wrench to remove the two nuts securing the fuel tank valve. Do not lose the sealing gasket.	
2	Inject pressure low	If there are quality issues with the fuel injector, it should be replaced. The fuel injection pressure of the fuel injector is $21 \pm 1$ MPa, which requires testing with specialized equipment. Refer to Part One: Difficulty in Starting Diesel Engines \ Fuel System Faults for the disassembly method.	
3	Timing is wrong	Disassembly Steps: 1. Use a 17mm wrench to remove the high-pressure fuel line. 2. Refer to Step 8 in the diesel engine wiring section to check if the fuel supply advance angle is correct. 3. Use a 6mm socket wrench to remove the nut of the fuel injector, and adjust the fuel supply advance angle by adding or removing shims.	
4	Fuel pump supply fuel insufficient	Without specialized equipment, it is not easy to judge the fuel supply of the fuel injection pump. You can observe whether the fuel output of the fuel injection pump is weak or not when pulling the starter rope. Usually, trying a new fuel injection pump is an option to consider.	17mm wrench

Project	Disassemble or Inspect Parts	Disassembly Steps and Precautions	Tools
B. Exhaust and intake system fault			
1	Leakage at the joint surface of the air filter	Leakage at the joint surface of the air filter	6mm ratchet wrench 6mm box wrench
2	Clogging of the air filter element	Clogging of the air filter element	/

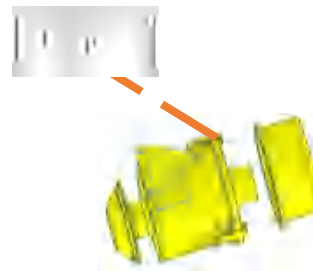
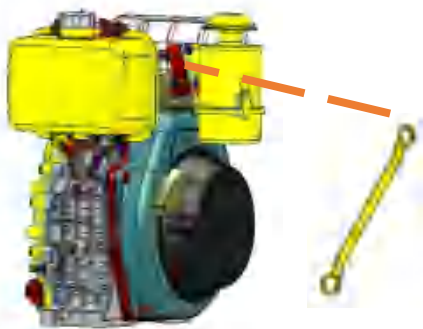

Project	Disassemble or Inspect Parts	Disassembly Steps and Precautions	Tools
1	Clogging and carbon deposition in the exhaust pipe outlet of the muffler	Use a 6mm socket wrench to remove the two bolts at the lower end of the muffler. Use a 13mm socket wrench to remove the two bolts at the upper end of the muffler.	6mm socket wrench 13mm socket wrench

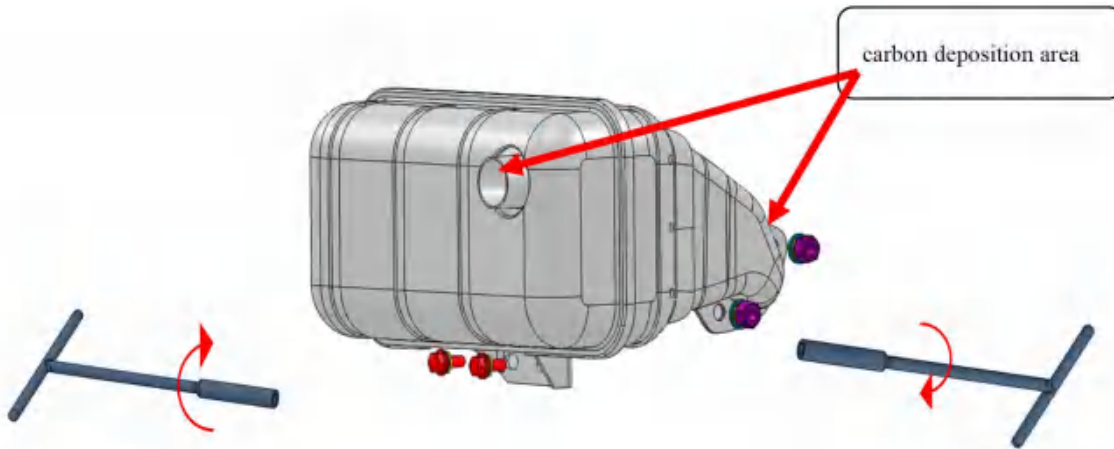

Project	Disassemble or Inspect Parts	Disassembly Steps and Precautions	Tools
C.Compress system fault			
1	Valve clearance too big or too small	Disassembly Steps: 1.First, use a 6mm socket wrench to remove the cylinder head cover, and place the gasket properly. 2.Loosen the valve adjustment nut with a 6mm box wrench, and place a 0.15mm thick feeler gauge between the valve lash adjustment screw and the valve cap. 3.Use the box wrench in your left hand to hold it steady, and use a flathead screwdriver in your right hand to rotate the valve lash adjustment screw. Withdraw the feeler gauge when you feel resistance. Note: When withdrawing the feeler gauge, it is incorrect if it comes out too easily or is too tight.	6mm socket wrench 0.15mm thick feeler gauge

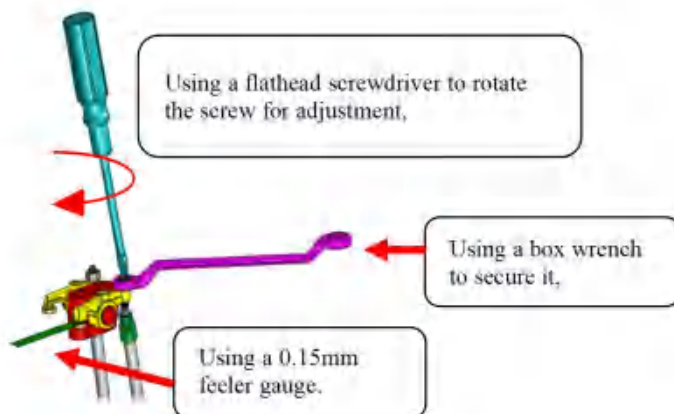

Project	Disassemble or Inspect Parts	Disassembly Steps and Precautions	Tools
2	Wear on piston, cylinder, and piston rings	After removing the cylinder head by referring to the disassembly method for the cylinder head, inspect the wear condition of the cylinder. Generally, faults related to the amount of wear are not considered first.	Torque wrench with 17mm socket and 6mm socket wrench
3	Leakage at the joint surface between the block and cylinder head	Refer to the disassembly method outlined in point 2 of section b on difficulties in starting a diesel engine for disassembly and repair.	Torque wrench with 17mm socket
4	Valve leakage	Valve wear or the presence of foreign matter at the valve.	

III. Unstable Operation of Diesel Engine: Mainly divided into a) Engine Knocking Sound and b) Detonation.

Project	Disassemble or Inspect Parts	Disassembly Steps and Precautions	Tools
1	The engine has a knocking sound.	<ol style="list-style-type: none"> <li>1.Excessive wear on piston, cylinder, or piston rings</li> <li>2.Excessive wear on piston pin and pin hole</li> <li>3.Excessive wear on the big and small ends of the connecting rod</li> <li>4.Excessive wear on the main journal of the crankshaft</li> </ol>	

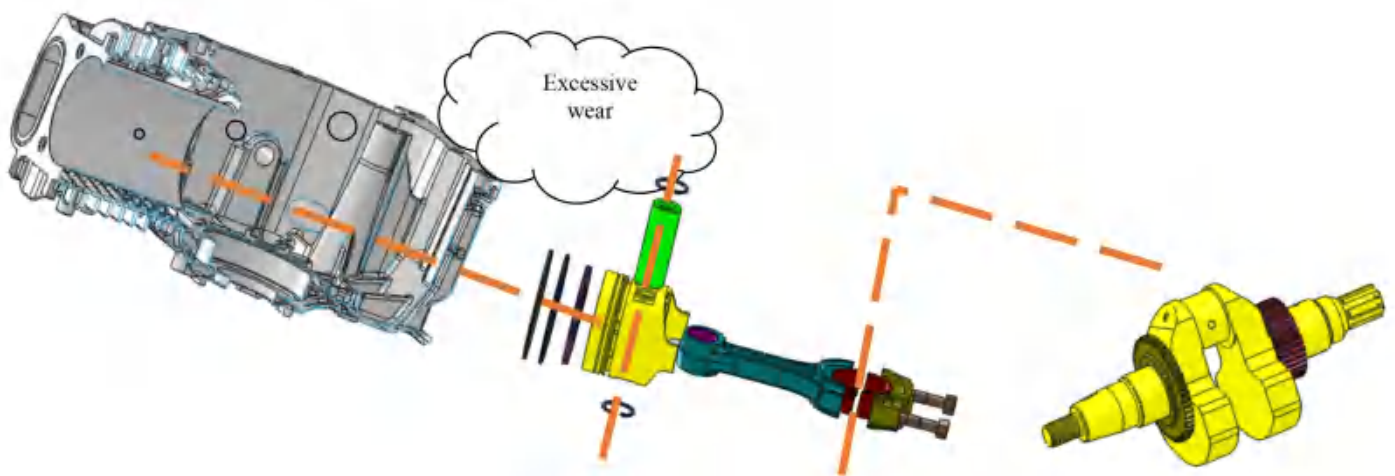

Project	Disassemble or Inspect Parts	Disassembly Steps and Precautions	Tools
1.1		<p>Disassembly of Crankshaft and Flywheel</p> <p>1. Disassemble in the following order: cylinder head cover - high-pressure fuel pipe - fuel tank - muffler - cylinder head - fuel injection pump. These steps have been introduced in previous maintenance procedures.</p> <p>2. After disassembling the fuel injection pump, proceed to disassemble the wind deflector, starting cup, and flywheel.</p> <p>3. Once the flywheel is disassembled, move to the front and disassemble the case cover, piston, retaining washer, flat key, and crankshaft.</p> <p>Note: During the disassembly process, avoid damaging the flywheel blades and crankshaft threads. Properly store important components or small parts such as flat keys, seals, gaskets, and fuel injection pumps. Prevent dust from entering and causing blockages or loss.</p>	<p>Puller or specialized flywheel extractor tooling, torque wrench capable of 180N·m or more, 10mm socket wrench, 24mm socket, and 22mm socket.</p>
2	Timing	<p>Advancing the Fuel Supply Advance Angle</p> <ol style="list-style-type: none"> <li>1) Remove the bolts of the wind deflector with a 10mm socket wrench.</li> <li>2) Remove the high-pressure fuel pipe with a 17mm wrench.</li> <li>3) Turn the flywheel to observe if the advance angle is correct.</li> </ol>	<p>10mm socket wrench 17mm wrench</p>

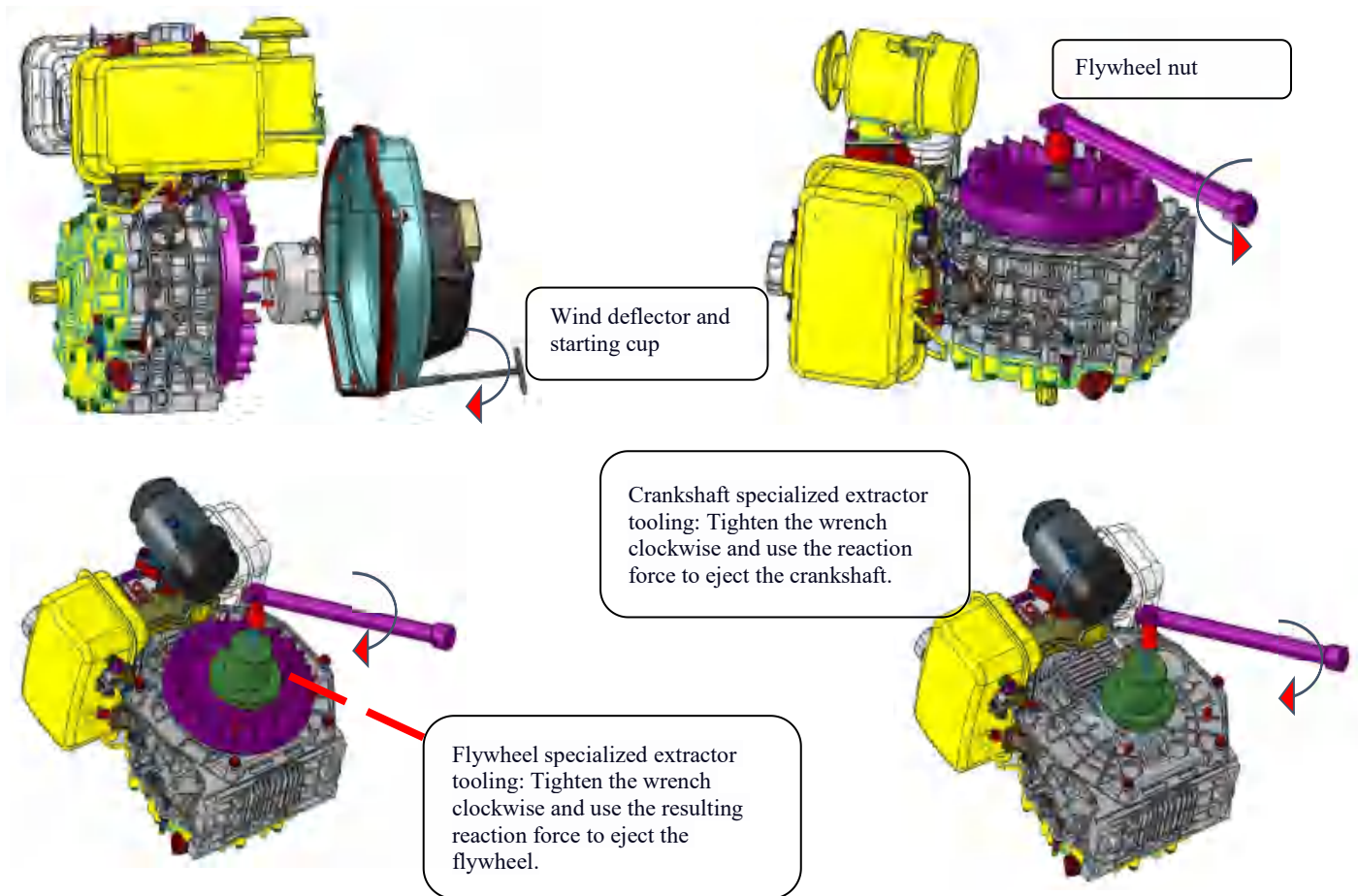

Project	Disassemble or Inspect Parts	Disassembly Steps and Precautions	Tools
B. Detonation			
1	Carbon deposition in the combustion chamber	Excessive carbon deposition can cause cylinder knocking. To address this, remove the cylinder head, pull the starter rope to rotate the piston to its highest point, and use a specialized tool to clean the carbon deposition on the piston surface. During the cleaning process, be careful not to scratch the piston surface or allow carbon deposits to fall into the piston sidewall.	
2	Water and other impurities in fuel	replace the fuel with clean ones	

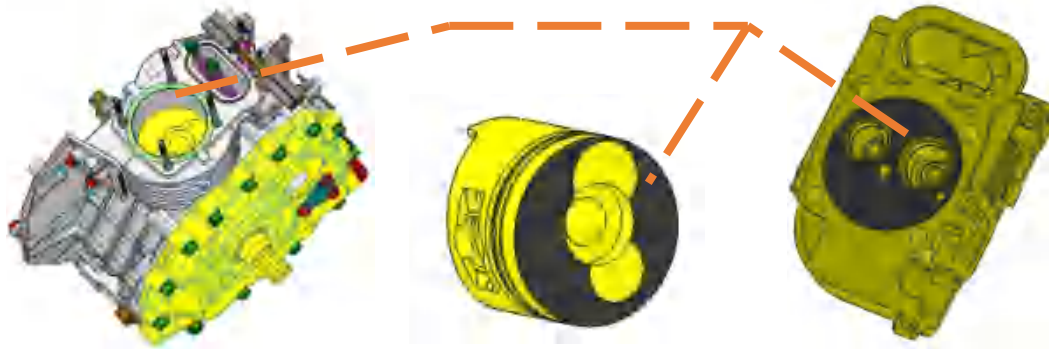

IV. Sudden Shutdown Fault During Diesel Engine Operation

Project	Disassemble or Inspect Parts	Disassembly Steps and Precautions	Tools
1	Sudden shutdown	Run out of fuel	
2	Unable to start after shutdown	1. Cylinder scoring 2. Valve dropout 3. Crankshaft fracture	

Cylinder scoring refers to the scratching and damage between the piston and the cylinder due to unstable operation or other reasons, resulting in obvious scratch marks.

Valve dropout: It refers to the situation where the valve clearance adjustment screw falls out from the head of the push rod.

Crankshaft fracture: It occurs when the power system is subjected to sudden loads exceeding the stored torque value, causing the crankshaft to break. The typical fracture locations are as shown in the diagram. This situation is relatively common in the power systems of mini-tillers, especially when

### V. Overheating Fault of Diesel Engine

Project	Disassemble or Inspect Parts	Disassembly Steps and Precautions	Tools
1	Overheating of Diesel Engine	Insufficient Cooling: 1) Oil depletion or insufficient oil level 2) Damaged flywheel blades 3) Cooling fins on the cylinder head clogged with mud or other foreign matter 4) Over-combustion or incomplete combustion caused by incorrect fuel injection advance angle	

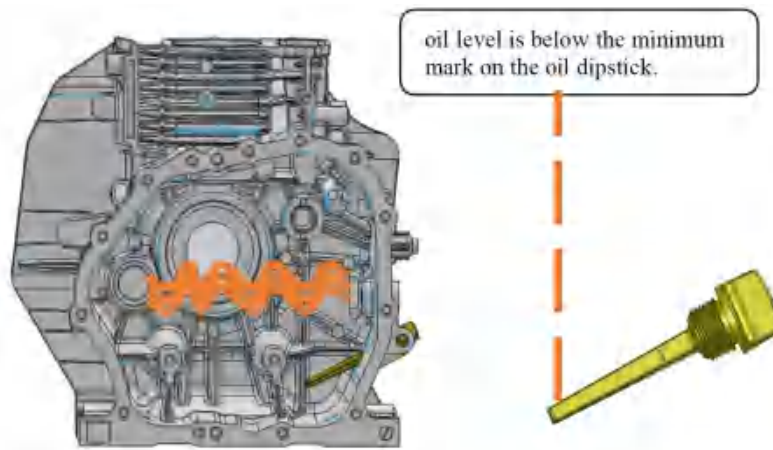

### VI. Abnormal Noises in Diesel Engine

Project	Disassemble or Inspect Parts	Disassembly Steps and Precautions	Tools
1		1. Improper Adjustment of Valve Clearance 2. Broken Connection Between Flywheel and Crankshaft 3. Foreign Objects Falling into the Gearbox or Gear Components with Impact Damage	

The difference between abnormal noise and unstable operation: Abnormal noise is caused by inadequate assembly control or foreign objects falling into the machine during the processes of assembly, packaging, and transportation, which does not constitute a performance issue of the diesel engine itself. For issues of abnormal noise, it is necessary to carefully listen to the location where the sound is emitted and disassemble components based on specific circumstances.

Project	Disassemble or Inspect Parts	Disassembly Steps and Precautions	Tools
1	Unstable idling	The speed control tension spring is not matched	
2	Rebound	The valve clearance is improperly adjusted	
3	Over-revving	The limiting bolt and lead seal of the speed control bracket have fallen off	
4	Emitting white smoke	<ol style="list-style-type: none"> <li>1) Water ingress in fuel (most common), replace the fuel</li> <li>2) Poor atomization of the fuel injector results in incomplete combustion of diesel fuel. This incompletely burned diesel mixes with the high-temperature exhaust gas from normally functioning cylinders in the exhaust pipe, causing white smoke. Clean or replace the fuel injector.</li> <li>3) Late fuel injection timing means that the cylinder temperature has already dropped when fuel is injected, causing some diesel to remain unburned and turn into oil vapor. Adjust the fuel supply advance angle.</li> </ol>	
5	Emitting black smoke	<ol style="list-style-type: none"> <li>1) The fuel supply advance angle is incorrect, adjust the fuel supply advance angle.</li> <li>2) Oil has entered the combustion chamber, possibly due to the machine being upside down or other reasons, causing a large amount of oil to mix in the combustion chamber and producing thick black smoke. Clean the oil out of the combustion chamber.</li> </ol>	
6	Emitting blue smoke	<ol style="list-style-type: none"> <li>1) Too much oil. Remove the oil dipstick to check if the oil level exceeds the upper mark significantly, and pour out the excess oil.</li> <li>2) The piston rings are severely worn or broken, causing oil to leak into the combustion chamber and burn. Replace the piston rings.</li> <li>3) The valves or valve guides are severely worn, causing oil to leak. Replace the valves or the cylinder head.</li> <li>4) The air filter is clogged, and the resistance caused by the clogged filter element creates a negative pressure in the cylinder, drawing oil into the combustion chamber. Clean or replace the air filter element.</li> </ol>	

VII. Other Faults of Diesel Engines

**Routine Maintenance and Servicing of Single-Cylinder Diesel Engines**

I. Daily Inspection and Maintenance

Check if the oil level is between the upper and lower limits.

Check for any oil leaks.

Clean the dirt and grease on the engine and its accessories to keep the engine

Rectify any faults found during operation.

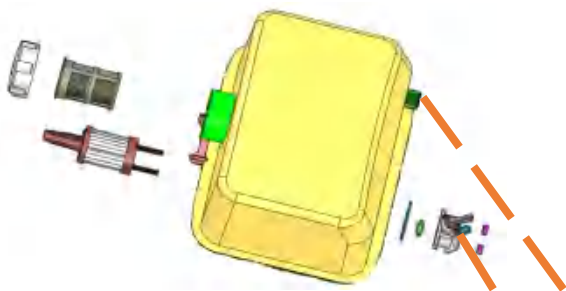
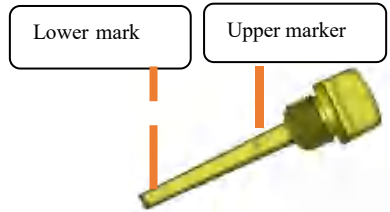

Key inspection areas: fuel tank valve, fuel delivery pipe, and oil drain pipe connectors.

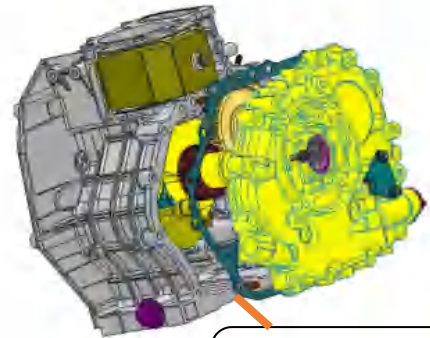

Key inspection area: the bottom of the junction between the gearbox body and cover.

II. Regular/Periodic Inspection

1. The fuel filter must be cleaned and replaced regularly to ensure maximum output power of the engine on a daily basis.

Clean	Every 6 months or 500h
Replace	One year or 1000h

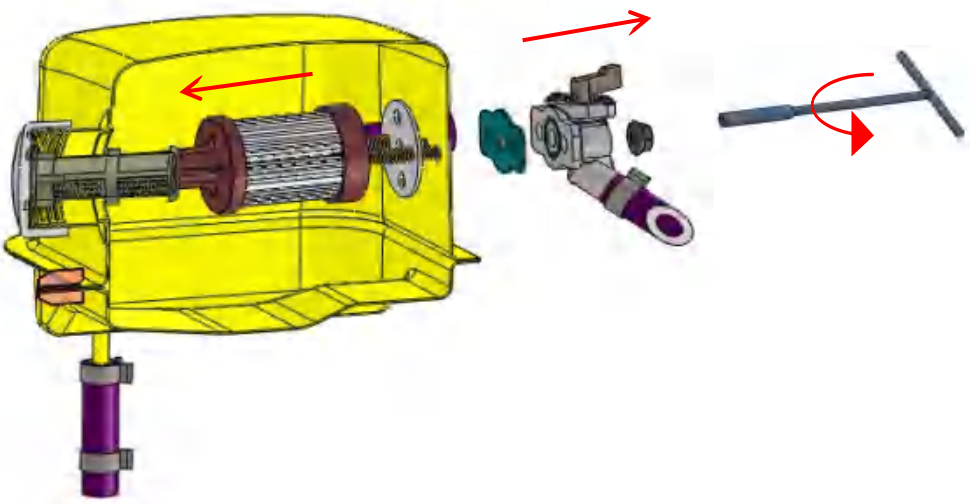

2. Cleaning or replacing the oil filter ensures the cleanliness of the oil, preventing issues such as cylinder lining scoring.

Clean	250h
Replace	500h

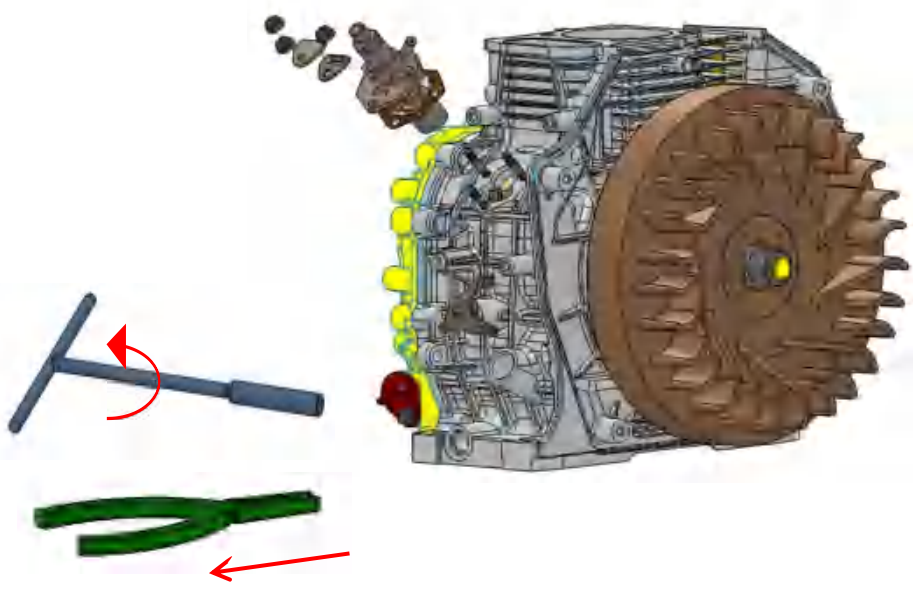

3. Oil replace

Replace	Every 6 months or 500h
First time	One year or 1000h
For the second time and subsequent times	Every three months or 100h

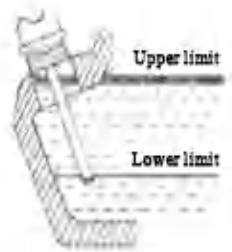

4. Clean or replace air filter

Replace	Every 6 months or 500h; If necessary, it can be replaced in advance.
---------	--

When the filter element of the air filter is clogged, it means that the air entering the combustion chamber is reduced, subsequently causing the engine's output power to decrease while increasing the consumption of fuel and lubricating oil. Additionally, the engine becomes harder to start.

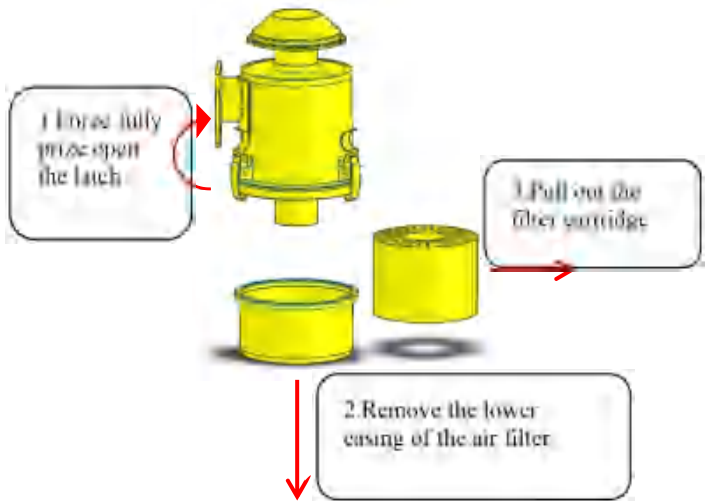

## RSAD292 series assemble

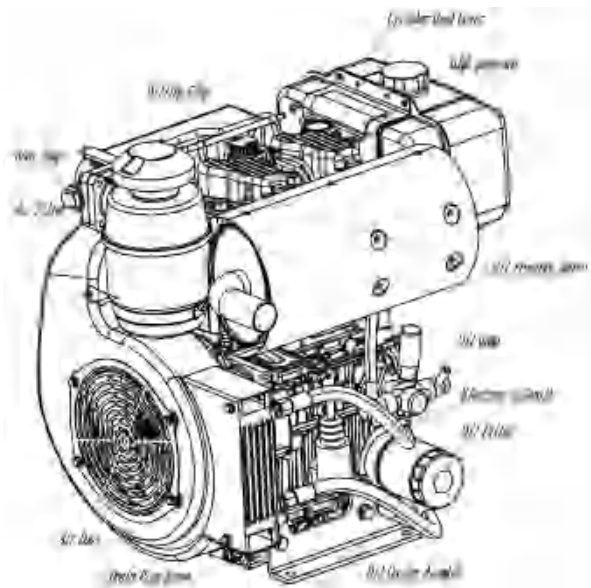
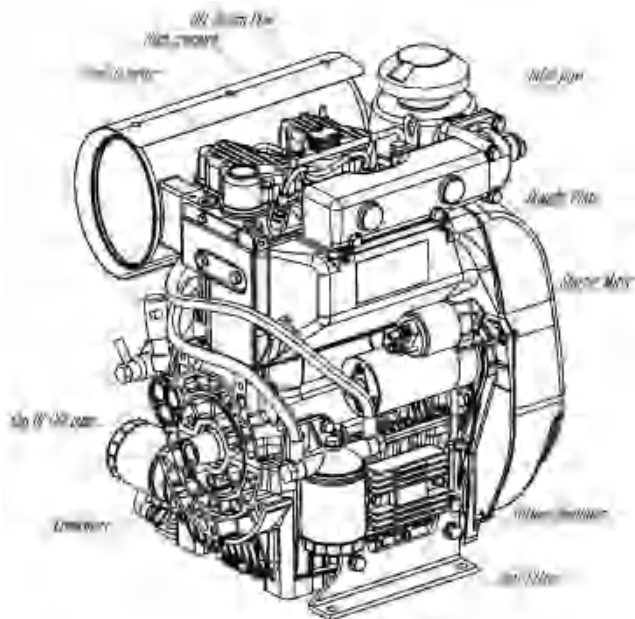

### 1. Transport

The lifting hook bolt provided as stand and equipment is intended for safe movement of the engine.

It is not intended for lifting complete machinery to which the engine is attached, and this is strictly forbidden.

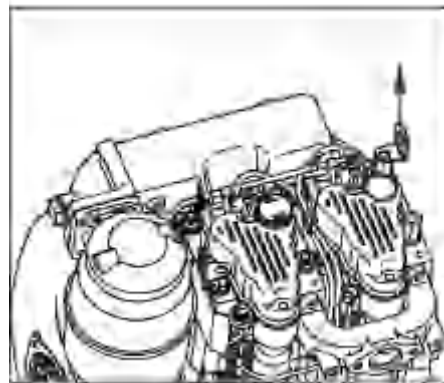

The permitted loads and elements on the speed adjusting lever and the stop lever should be observed as an excess can lead to damage to the contacts and inner governor parts.

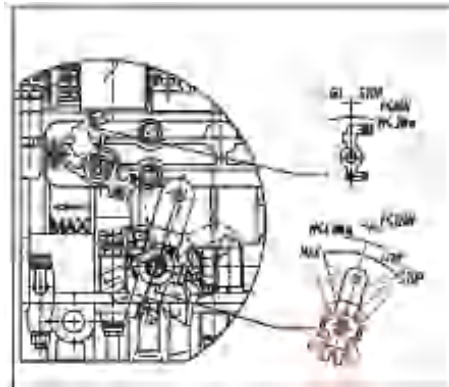

## 2. Operation

### 2.1 Before initial start-up

Engines are normally delivered without fuel and oil.

#### 2.1.1 Engine oil

##### Oil quality

Qualified are all trademark oils which fulfill at least one of the following

##### Specifications:

API-CF/CF-4/CG-4 or more significant.

If engine oil of a poorer quality is used, reduce oil change intervals to 150 hours of operation.

##### Oil viscosity

#### 2.1.2 Oil viscosity

Please select the recommended viscosity depending on the ambient temperature at which the engine is operated.

**Inappropriate engine oil may shorten the engine's service life significantly. When adding oil or checking the level, the engine must be in a horizontal position.**

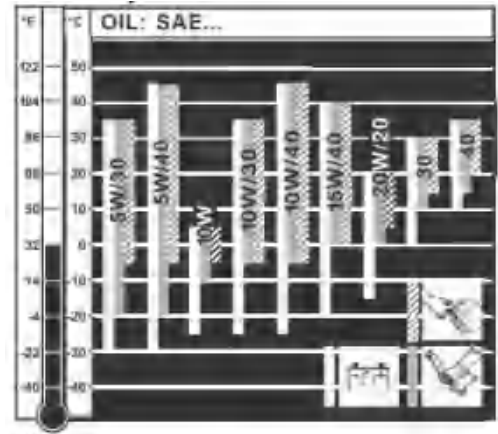

- Remove oil filler screw .1" and dipstick .2.
- Add engine oil up to the max. mark on the dipstick.
- Lubricating oil capacity: see Chapter 3.1.
- Insert the oil filler screw and tighten it (hand-tight only).

##### Attention!

**The engine is operated while the oil level is below the min. mark or above the max. Mark, it can cause damage to the engine.**

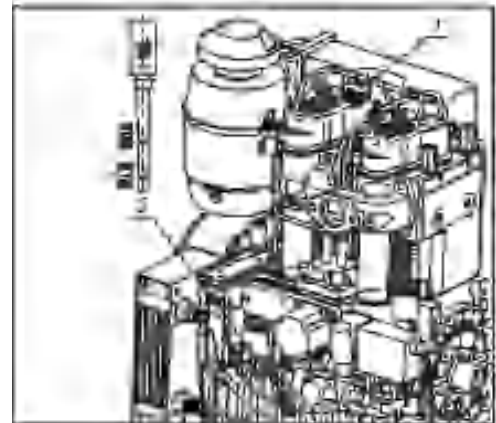

### 2.1.3 Oil bath air cleaner

If a cyclone-type dust trap is fitted, make sure that the dust outlet is pointing in the correct direction.

- Fill the oil tank up to mark with engine oil.

Attach oil tank, making sure that sealing ring is correctly seated and clips are fastened securely.

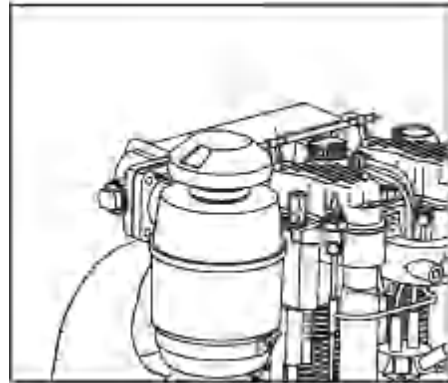

### 2.1.4 Fuel



Stop the engine before refueling. Never add fuel near a naked flame or a source of sparks. Don't smoke. Use only pure fuel and clean filling equipment. Take care not to spill fuel.

**Important !The use of fuels of different specifications requires the prior written consent of the headquarters.**

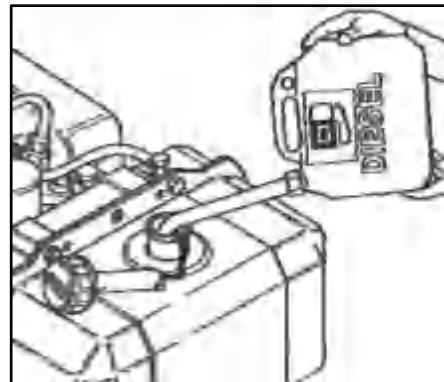

Before starting for the first time or if the fuel system was run dry, prime it by operating lever. "1" on feed pump "2" until fuel is heard to flow back into the fuel tank through the return line.

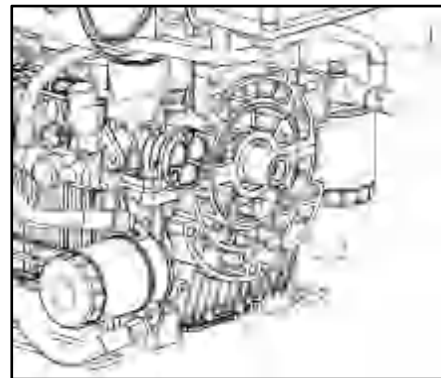

### 2.2 Starting the engine



Do not run the engine in closed adorably ventilated rooms - danger of poisoning!

Before starting the engine, make sure that no one is within the danger area near the engine or the machinery it is driving, and that all the necessary guards are installed.

### 2.2.1 Preparations for starting

- Depending on operation conditions and requirement, set speed control lever "1" to either the 1/2 START or max, START position.
- Make sure that stop lever 2" is in the off position START".

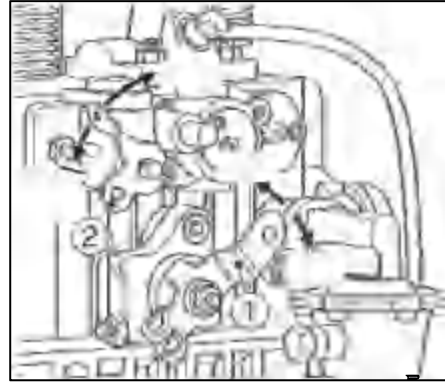

**Never use starting aids in the form of aerosols or sprays !**

### 2.2.2 Electric starter

- For starting preparations, see Chapter 2.2.1.
  - Insert the start key to its stop and turn it to position.
  - Turn start key to position
  - As soon as the engine runs, release the start key. It must return to position by itself and remain in this position during operation.
  - The air cleaner maintenance indicator (additional equipment) only lights up during operation if the air cleaner element needs to be cleaned or renewed.
- Always turn the start key back to position 0 before restarting the engine. The repeat lock in the ignition lock prevents the starter motor from engaging and possibly being damaged while the engine is still running.

#### **Important !**

If a starter protection module is fitted, the key must be turned back to position 0 for at least 8 seconds if the engine fails to start, before a second attempt of starting can be made.

Note: Start for max. 30 seconds. If the engine does not run after this time, turn starter key back to position 0 and eliminate the cause.

Preheating device with automatic heating timer (additional equipment)

Automatic shut-down function (additional equipment)

Important

Even with automatic shutdown monitoring the oil level must be checked every 8- 15 operating hours.

## 2.3 Stopping the engine

- Move speed control lever "1" back to the "STOP" position.
- On engines with the lower idling speed out of use, move speed control lever ,1" back, then move stop lever ,2" towards STOP and hold it there until the engine has come to a standstill.
- Once the engine is not running any longer, release the stop lever. The stop lever is returned automatically to its operating position START via a spring.

Move speed control lever "1" back to the "STOP" position  
**Note:**Engines with an automatic electrical shut down system can also be stopped by turning the starter key back to position.

**During breaks in operation or at the end of the work session, pull out the starter key and keep in a safe place where it cannot be reached by unauthorized Persons.**

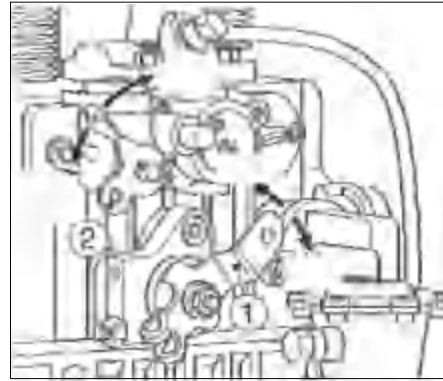

## 3. Maintenance

### 3.1 Check engine oil level

When the oil level is checked, the engine must be stopped and in a horizontal position.

- Remove any dirt in the dipstick area.
- For oil level inspection, remove the dipstick and wipe it dry using a lint-free, clean piece of cloth; then insert it to its stop and pull it out again.
- Check oil level at the dipstick; top up if necessary as far as the "max" mark (see Chapter 4.1.1.).

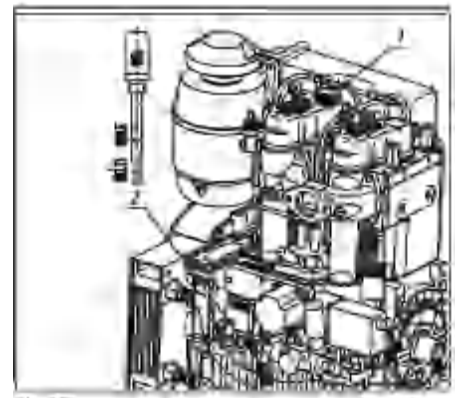

#### **Attention!**

If the engine is operated while the oil level is below the min. mark or above the max. Mark it can cause damage to the engine.

### 3.2 Check combustion air intake area

Heavy contamination is an indication that increased dust accumulation necessitates a correspondingly shorter maintenance interval.

- Inspect air inlets (depending on version) for severe dirt and dust deposits, and clean if necessary.
- Make sure that dust outlet on the cyclone-type dust trap (depending on version) is not obstructed, and clean if necessary (chap. 5.3.1.).
- Inspect air inlets and clean if necessary
- Check that dust discharge valve is not obstructed; eliminate dust blockage by pressing together as shown.

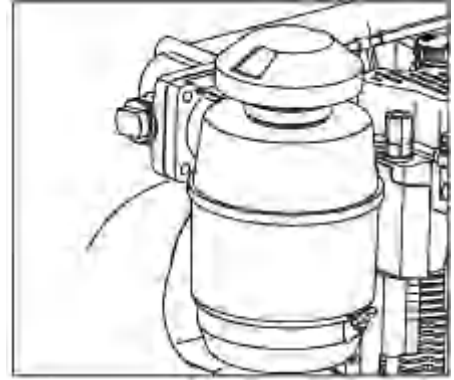

### 3.3 Maintenance work every 250 operating hours

**Trap the old oil and dispose of it in accordance with local legislation.**

- Take off the oil tank.
- Remove contaminated oil and sludge from the oil tank, and clean it out.
- Take off rain cap or cyclone-type dust trap, and clean.
- Clean right through intake pipe
- Check condition of sealing ring and renew if necessary.
- Add engine oil to the oil tank up to mark and re-assemble the oil bath air cleaner

If the filter packing is severely contaminated with dust and dirt, the upper part of the air cleaner must also be cleaned as follows.

- Detach upper part of air cleaner from engine and rinse in diesel fuel.
- Allow the diesel fuel drip off thoroughly, or wipe it off, before re-assembling
- Install a new filter packing if the sealing surface is uneven, the body of the filter is cracked or the filter wool is missing.
- Install the upper part of the air cleaner, using a new flange gasket
- Re-assemble the remaining parts of the air cleaner and fill with oil to prepare for further

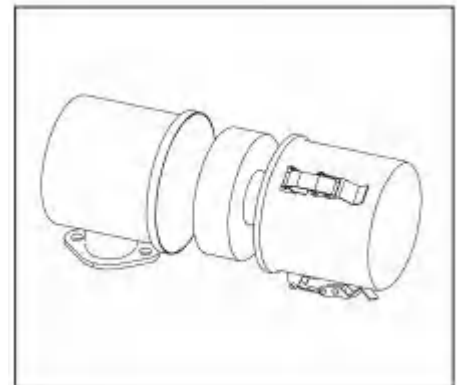

### 3.4 Engine oil change and oil filter renewal

The engine must be stopped and in a horizontal position. Drain the engine oil only when the engine is warm.

- Take out drain plug "1" and allow the oil to drain out completely.
- Insert oil drain plug "1" with a new sealing ring "2" and tighten.



- Slacken off and unscrew the throwaway engine oil filter using strap wrench, 1, Order No.620 307 01, or a similar tool.
- After cleaning, press the mesh screen back on to the oil pressure relief valve.

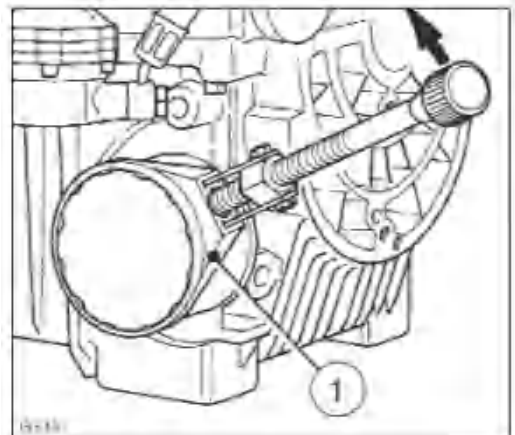

- Clean sealing face "1" thoroughly
- Never re-use the throwaway filter element oil sealing ring "2" on the new filter element lightly.
- Screw in throwaway filter element "3" hand tight.
- Add engine oil (chap. 4.1.1.)
- Run the engine briefly to check that there are no leaks at the oil filter; take up slack necessary.
- Check the oil level; add oil if necessary(chap.5.2.1.).

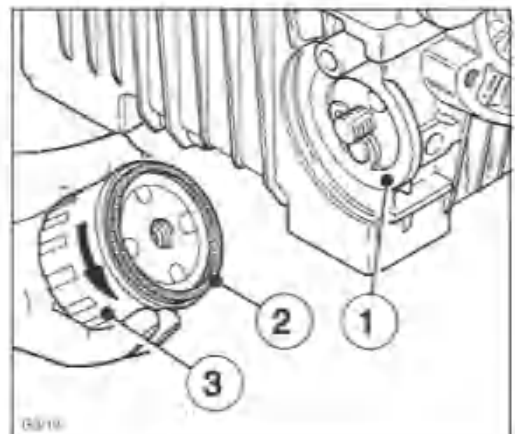

### 3.5 Check and adjust valve clearances

- Adjust only when the engine is cold(10-30°C).
- Remove any dirt from the area where the cover is attached to the cylinder head.
- Remove screws ,1“ and take off cover,3" complete with sealing rings ,2" and.4".Never re-use these sealing rings.

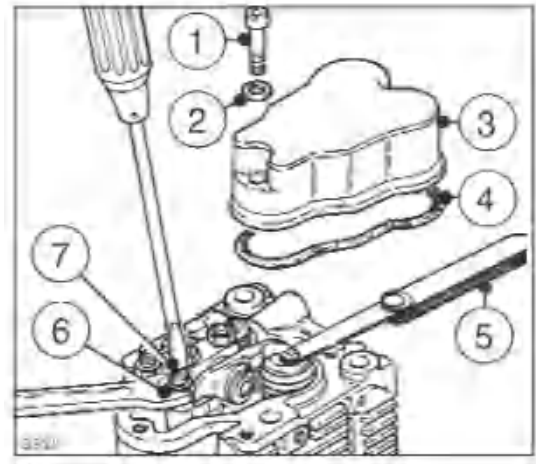

#### Adjusting procedure:

- Cylinder 1 is at the flywheel end;clockwise rotation.Cylinder 2 is at the power take-off end;anti-clockwise rotation.
- Turn the engine in its normal direction of rotation until the valves in cylinder 2 are in the overlap position(exhaust valve not yet closed inlet valve starts to open).
- Turn the crankshaft through 180 degrees in the normal direction of rotation, then check valve clearances for cylinder 1 and adjust if necessary
- Turn the crankshaft through a further 180degrees; check valve clearances for cylinder2 and adjust if necessary.

#### Adjusting:

- Measure valve clearance with 0.10 mm feeler gauge“5“(fig.21,chap.3.1).
- If adjustment is necessary, slacken off hex nut“6“, turn adjusting screw “7“and re tighten nut“6“. It should then be possible to pull feeler gauge“5“through with just perceptible resistance to movement (fig. 21).
- Replace the cover in position and tighten it down uniformly.
- Run the engine briefly to check that there are no leaks at the cover.

### 3.6 Clean the cooling air system

- Take off all air guides.

#### If dirt deposits are dry:

- Clean all air guides and the entire cooling air system including cylinder heads, cylinder and flywheel blades without making them wet,and blow them through with compressed air.

**Persons handling compressed air must wear protective goggles. Never direct the jet to animals, persons or yourself!**

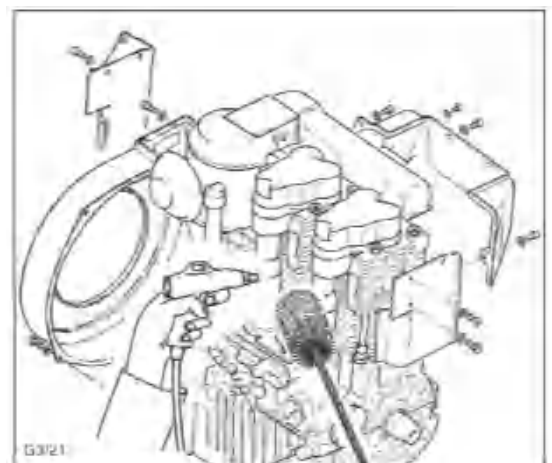

**If dirt deposits are damp or oily:-**

Disconnect the battery.

-Apply a detergent solution(cold cleaner or similar) to the entire system in accordance with the manufacturer's instructions, then spray off with a powerful water jet. Do not splash electrical device with water jet or pressure jet during engine cleaning

-Establish the cause of contamination with oil and have any leaks repaired.

Re-attach all air guides.

**The engine must never be run without the air guides.**

-Run the engine immediately after re-assembly until it is warm; this will prevent rust from forming.

**3.7 Check threaded connections**

Check the condition and tightness of all threaded connections, pipes and lines, hose clips and other fastenings on the engine or its mountings which can be reached during maintenance work.

**Do not tighten the cylinder head bolts.**

**The adjusting screws at the engine governor and on the injection system are sealed with lacquer or with lead and are not to be tightened or adjusted.**

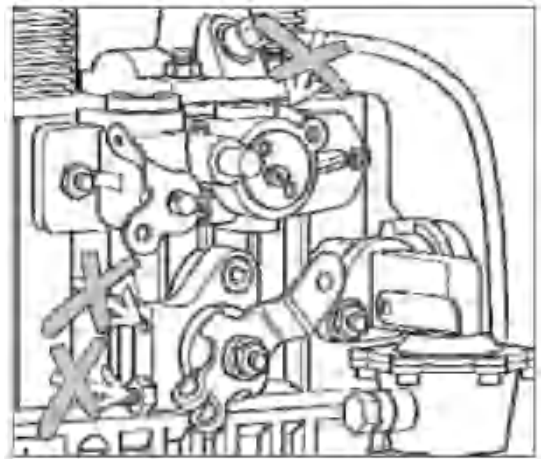

**3.8 Maintenance work every 500 hours of operation**

The maintenance intervals for the fuel filter are dependent upon the purity of the diesel oil being used and, if necessary, may have to be reduced to 250 hours.

**When working on the fuel system, do not expose it to naked flames; do not smoke..**

Important !Keep the entire area clean so that no dirt reaches the fuel. Fuel particles may damage the injection system.

- Shut off the fuel supply.

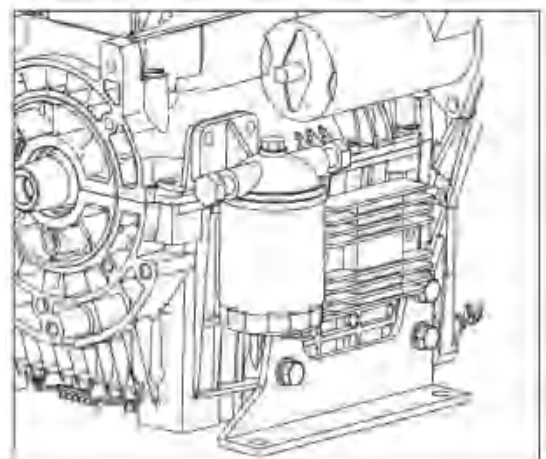

-Pull fuel feed line off fuel filter , at both sides,and insert a new filter. Make sure that the direction of fuel flow is as shown by the arrows.

-Open up the fuel supply again and if necessary operate the priming pump (chap. 4.1.3.).

-Run the engine briefly to check that there are no leaks at the fuel filter and fuel lines

**Raywin Powertrain Technology Co., Ltd**

**Add:NO.99jiujiang Rd,Shuangfu District,Jiangjin District,Chongqing,China**

**Tel: +86-23-85553153**

**Email: [info@raywin.cc](mailto:info@raywin.cc)**

**Website:<http://www.raywinpower.com>**