

4D24TG-4, 4D24T-4 Series Diesel Engines (China IV)

User and Maintenance Manual

Please read the user manual carefully before use

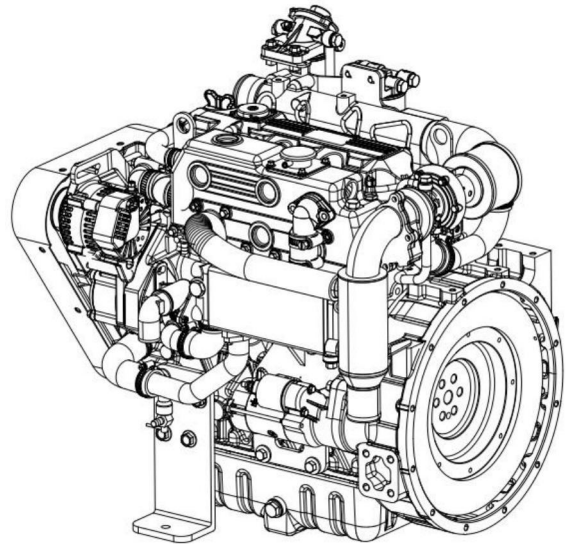
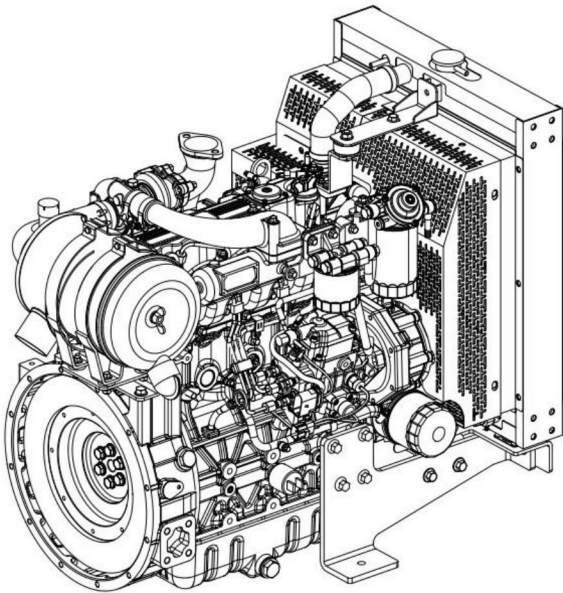

Preface

The 4D24TG-4 series diesel engine is a National IV engine jointly developed by Runway Engine (Chongqing) Co., Ltd. and internationally renowned engine research institutions and expert groups. It adopts a two-valve, turbocharged technology, as well as an electronic control rotary pump fuel system, meeting National Stage IV emission standards and holding certifications. It features excellent reliability, fuel economy, power performance, and meets the fixed constant-speed power application needs of various markets such as land-based power generation and marine power generation.

This manual provides basic knowledge on the use and maintenance of the 4D24TG-4 series diesel engine for both land and marine applications, as well as common faults and their troubleshooting methods for your reference. To ensure the 4D24TG-4 series diesel engine serves you better and fully realizes its effectiveness, please thoroughly understand the structure of the diesel engine and master its maintenance and operation methods. If you can conscientiously follow the maintenance procedures, it will greatly extend the service life of the diesel engine.

With the continuous increase and improvement of the model varieties of the 4D24TG-4 series diesel engine, it is not possible to notify every improvement made. We sincerely ask for the attention and understanding of all users.

The right of interpretation of this manual belongs to Raywin Powertrain Technology Co., Ltd.

Content

1. Introduction	3
2. Overview	6
2.1 Genset Power	6
2.2 Marine Generator Power	9
3. Fuel, oil, coolant, and auxiliary materials used in the diesel engine	11
3.1 Fuel	11
3.2 Engine Oil	11
3.3 Antifreeze	13
3.4 Selection of Storage Battery	15
4. Installation, Operation, and Maintenance of the Diesel Engine	16
4.1 Operation of the Diesel Engine	16
4.2 Use and Regular Maintenance of Land-Based Diesel Engines	18
4.2.1 Engine Break-in	19
4.2.2 Maintenance and Care of Diesel Engines	19
4.2.2.1 Maintenance intervals shall be in accordance with the following table	20
4.3 Use and regular maintenance of marine diesel engines	21
4.3.1 Marine Diesel Engine Heat Exchange System	21
4.3.3 Smoke-water mixer (after-vortex cooler)	22
5. Daily Maintenance and Care Instructions for Diesel Engines	22
5.1 Cooling System Coolant Level Check	22
5.2 Cooling Fan	23
5.3 Fuel Filter	23
5.4 Engine Oil Level Check	23
5.5 Drive Belt Inspection	24
5.6 Air Filter	25
5.7 Valve Train	25
6. Common trouble of diesel engine and removal methods	26
6.1 Diesel engine cannot start	27
6.2 Hard to start	30
6.3 Diesel engine insufficient power	30
6.4 Abnormal sound during running	33
6.5 Exhaust smoke	34
6.6 White and blue smoke	36
6.7 Oil pressure anomaly	39
6.8 High oil consumption	41
6.9 Cooling water temperature too high (alarm)	41
6.10 Common failure of turbocharger and its Trouble shooting	42
6.11 Diesel engine self extinguishing	43
6.12 Diesel engine vibration	46
6.13 Unstable idle speed of diesel engine	48
6.14 Oil dilution	50
6.15 System lamp / fault lamp is always light (Stanadyne fuel pump has no such steps)	50

1. Introduction

To Users and Operators

The relevant survey results indicate:

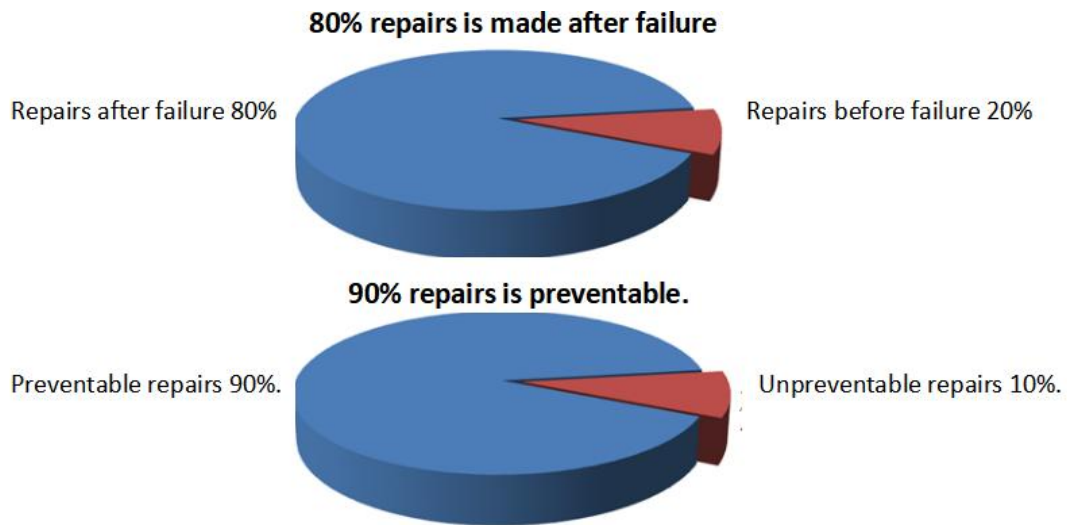

Preventive maintenance is very simple and inexpensive. Please follow the recommended maintenance specifications in the maintenance section of this manual and keep records of regular preventive maintenance.

Use the correct fuel, engine oil, and coolant as specified in this manual. For diesel engines equipped with aftertreatment systems, mixing engine oil and fuel is prohibited.

Note

When welding on the chassis or unit frame, remove the battery positive and negative cables from the battery and disconnect all connectors on the ECU according to the power removal procedure to prevent damage to the ECU during welding. Do not disconnect the ECU with power, and do not perform welding operations on the diesel engine or components installed on the diesel engine, otherwise the diesel engine or components may be damaged.

Symbol Explanation: The following symbols in this manual are used to help understand the meaning of various instructions. When any of the following symbols appears, it expresses the following specific meaning:



Warning - If this instruction is not followed, it may cause serious personal injury or significant property damage.

Δ Note - If this instruction is not followed, it may cause general personal injury or damage to parts, assemblies, or diesel engines.

Illustration Note: Some illustrations in this manual are illustrative and may differ from the diesel engine or parts you actually use.

General Safety Rules



Improper procedures, carelessness, or ignoring warning signs may cause burns, cuts, limb amputation, suffocation, or other personal injuries, even death.

Before performing maintenance, carefully read and understand all safety precautions and warnings. The following content includes general safety measures that must be followed to ensure personal safety. Specific safety measures will be included in the steps of implementation.

- ◆ The maintenance work area should be dry, well-lit, well-ventilated, free of clutter, scattered tools, parts, open flames, and other hazardous materials. Be aware of potential hazards.
- ◆ Never touch rotating parts, as they may cause cuts, limb amputations, or even death.
- ◆ Do not attempt to rotate the crankshaft by turning or prying the fan. This practice may cause serious personal injury, property damage, or damage to the fan blades, leading to premature fan failure.
- ◆ If the diesel engine has been running for a period of time and the coolant is hot, the diesel engine should be allowed to cool down gradually before slowly loosening the filler cap to release the pressure in the cooling system. Otherwise, it may cause burns or other personal injuries.
- ◆ Corrosion inhibitors (coolant additives and components in engine oil) contain alkali. Do not allow these substances to enter your eyes. Avoid prolonged and repeated skin contact. Do not ingest. If contact occurs, immediately rinse the skin with soap and water. If it gets into your eyes, immediately rinse with plenty of water for at least fifteen minutes. And seek medical attention immediately. Keep it out of reach of children.
- ◆ To reduce the risk of burns, be careful not to touch hot parts, exhaust pipes, hot liquids in the pipes, or the engine compartment immediately after the diesel engine has been shut down.
- ◆ When replacing fasteners, always use fasteners with the same part number (or equivalent products). If replacement is necessary, do not use lower-quality fasteners.
- ◆ Avoid inhaling engine oil fumes, swallowing it accidentally, and prolonged contact with used engine oil.
- ◆ Do not connect crossover start cables or battery charging cables to any ignition or speed control wires. This may cause electrical damage to the ignition or speed control system.
- ◆ Always tighten fasteners and fuel connections according to technical specifications; overtightening or undertightening can both lead to leaks.
- ◆ Since the odor of leaking fuel may gradually fade, always test for fuel leaks using the method specified.
- ◆ The coolant is toxic. If it is no longer in use, it should be disposed of in accordance with local environmental regulations.

2. Overview

2.1 Genset Power

4D24TG-4 series diesel engines are used for power generation in land-based units, with power ranging from 18.5kW to 36kW;

2.1.1 Composition and Meaning of Model Numbers

Product model numbers are represented by Arabic numerals and uppercase English letters, with the following composition structure: For example: 4D24TG0-4

4-----4 cylinders

D----product series code

24—2.4 L

T-----Exhaust Gas Turbocharged

G-----For Power Generation

0-----Type Code

2.1.2 Structure and Appearance

1. Radiator
2. Cylinder head cover
3. Turbocharger
4. Exhaust pipe cover
5. Air filter
6. Flywheel housing
7. Starting motor
8. Oil pan

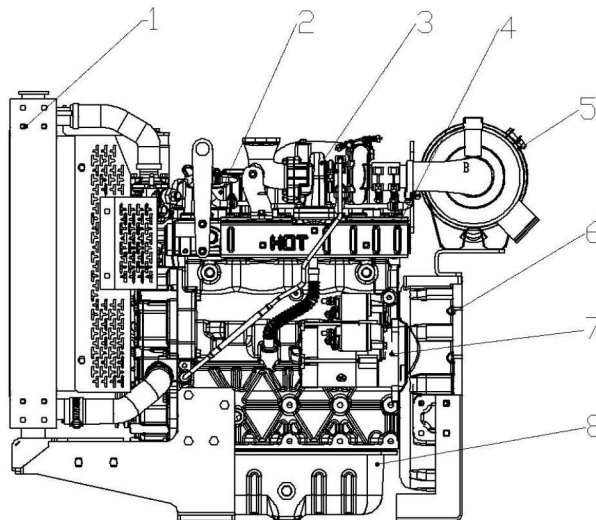

1. Intake pipe
2. Fuel filter
3. Fuel pre-filter
4. Fuel injection pump
5. Oil filter

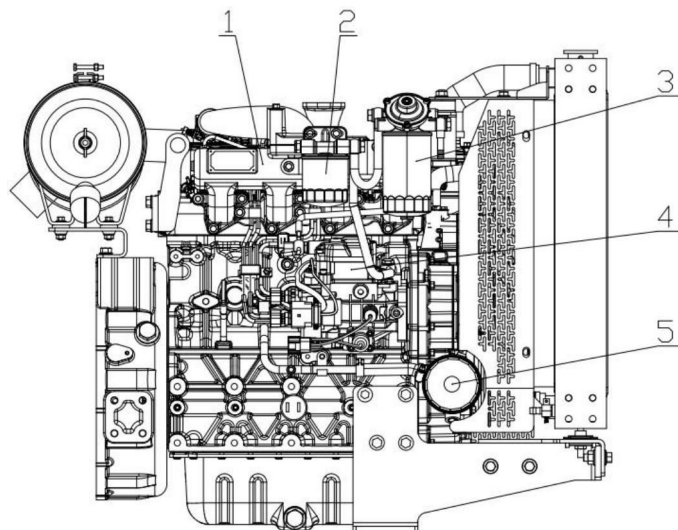

2.1.3 Technical Characteristics

Table 2-1 Main Technical Parameters of 4D24TG-4 Series Land-Use Diesel Generators

NO.	Item	Main Technical Parameters	
1	Model	4D24TG-4 Series	
2	Type	Vertical, inline, water-cooled, four-stroke	
3	Intake method	Turbocharged	
4	Combustion chamber type	Direct injection	
5	Number of cylinders (cylinders)	4	
6	Number of valves per cylinder (individual)	2	
7	Cylinder diameter (mm)	87	
8	Piston stroke (mm)	103	
9	Total piston displacement (L)	2.449	
10	Compression ratio	17.8	
11	Cylinder type	No cylinder liner	
12	Lubrication method	Pressure and splash mixed	
13	Starting method	Electric start	
14	Cooling method	Forced water cooling closed loop	
15	Work sequence	1-3-4-2	
16	Crankshaft rotation direction	Counterclockwise (facing the flywheel end)	
17	Power range (kW)	4D24TG0-4	36kW/1500rpm
		4D24TG1-4	32kW/1500rpm
		4D24TG2-4	28kW/1500rpm
		4D24TG3-4	23kW/1500rpm
		4D24TG4-4	18.5kW/1500rpm
		4D24TG5-4	36kW/1800rpm
		4D24TG6-4	32kW/1800rpm
		4D24TG7-4	28kW/1800rpm
		4D24TG8-4	23kW/1800rpm
4D24TG9-4	18.5kW/1800rpm		
18	Speed control method	Elector-control	
19	Fuel system	Electronically controlled vane pump (VP)	
20	Engine oil consumption rate (g/(kW ·h))	≤0.2	
21	Emission level	Non-road National IV	
22	Engine oil capacity (L)	9.5	
23	Net weight (kg)	265	
24	Dimensions (L×W×H) (mm)	1002×573×804	
25	Operating temperature range	-40 ~ 50°C (Heating auxiliary device required when ≤-10°C)	
26	Use altitude range	Recommended for use below 2000m, power correction is required for exceeding	

Table 2-2 Main technical parameters of 4D24T-4 series industrial diesel engine

NO.	Item	Main Technical Parameters	
1	Model	4D24T-4 Series	
2	Type	Vertical, inline, water-cooled, four-stroke	
3	Intake method	Turbocharged	
4	Combustion chamber type	Direct injection	
5	Number of cylinders (cylinders)	4	
6	Number of valves per cylinder (individual)	2	
7	Cylinder diameter (mm)	87	
8	Piston stroke (mm)	103	
9	Total piston displacement (L)	2.449	
10	Compression ratio	17.8	
11	Cylinder type	No cylinder liner	
12	Lubrication method	Pressure and splash mixed	
13	Starting method	Electric start	
14	Cooling method	Forced water cooling closed loop	
15	Work sequence	1-3-4-2	
16	Crankshaft rotation direction	Counterclockwise (facing the flywheel end)	
17	Power range (kW)	4D24T00-4	36.8kW/2000rpm
		4D24T01-4	36.8kW/1800rpm
		4D24T02-4	36.8kW/2200rpm
		4D24T03-4	36.8kW/2400rpm
		4D24T04-4	36.8kW/2600rpm
		4D24T05-4	36.8kW/2800rpm
		4D2400-4	36kW/2400rpm
		4D2412-4	28.5kW/1800rpm
18	Speed control method	Electro-control	
19	Fuel system	Electronically controlled vane pump (VP)	
20	Engine oil consumption rate (g/(kW ·h))	≤0.2	
21	Emission level	Non-road National IV	
22	Engine oil capacity (L)	9.5	
23	Net weight (kg)	265	
24	Dimensions (L×W×H) (mm)	1002×573×804	
25	Operating temperature range	-40 ~ 50°C (Heating auxiliary device required when ≤-10°C)	
26	Use altitude range	Recommended for use below 2000m, power correction is required for exceeding	

2.2 Marine Generator Power

The 4D24TG-4 series diesel engines are widely used in marine generator sets, which can provide high-quality and reliable power for ships.

4D24TG-4 series marine engine for shipboard units, with power ranging from 18.5kW to 36kW;

2.2.1 Structural Appearance

- 1.Intake Pipe
- 2.Fuel Filter
- 3.Fuel Pre-filter
- 4.Belt guard
- 5.Fuel injection pump
- 6.Gear house
- 7.Oil filter
- 8.Oil pressure sensor
- 9.Oil pan
- 10.Flywheel housing
- 11.Oil level indicator
12. Turbocharger compressor inlet pipe
- 13.Air filter

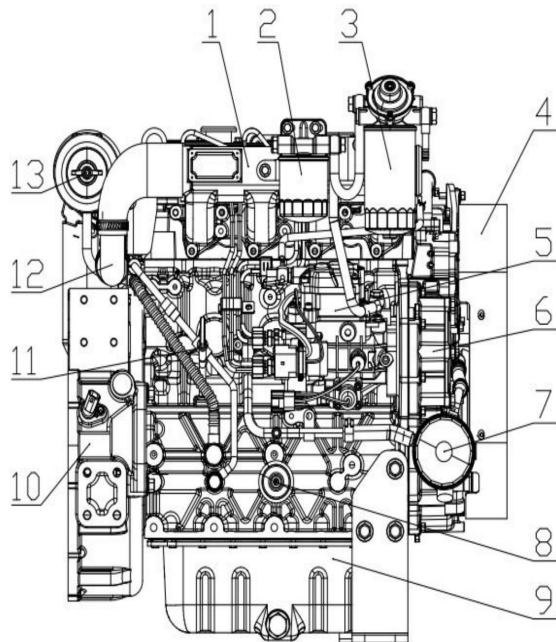

- 1.Water jacket exhaust pipe
- 2.Temperature
- 3.Turbocharger
- 4.Seawater discharge pipe
- 5.Smoke-water mixer
- 6.Water-cooled heat exchanger
- 7.Starter
- 8.Seawater pump
- 9.Cylinder block
- 10.Generator

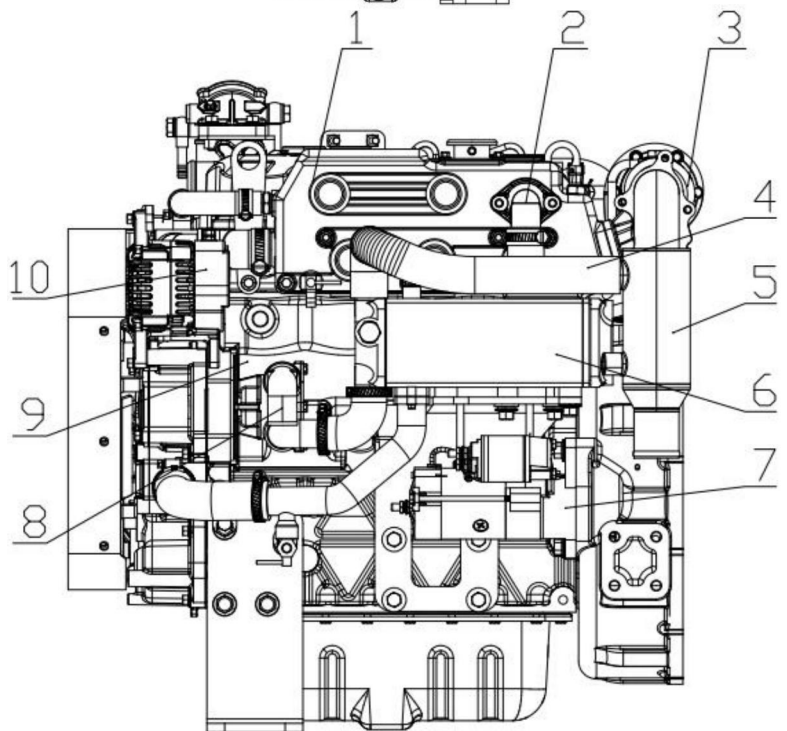

2.2.3 Technical Characteristics

Table 2-3 Main technical parameters of 4D24TG-4 series marine diesel generator

NO.	Item	Main Technical Parameters	
1	Model	4D24T-4 Series	
2	Type	Vertical, inline, water-cooled, four-stroke	
3	Intake method	Turbocharged	
4	Combustion chamber type	Direct injection	
5	Number of cylinders (cylinders)	4	
6	Number of valves per cylinder (individual)	2	
7	Cylinder diameter (mm)	87	
8	Piston stroke (mm)	103	
9	Total piston displacement (L)	2.449	
10	Compression ratio	17.8	
11	Cylinder type	No cylinder liner	
12	Lubrication method	Pressure and splash mixed	
13	Starting method	Electric start	
14	Cooling method	Forced water cooling + seawater pump heat exchanger system	
15	Work sequence	1-3-4-2	
16	Crankshaft rotation direction	Counterclockwise (facing the flywheel end)	
17.	Power range (kW)	4D24TG0-4	36kW/1500rpm
		4D24TG1-4	32kW/1500rpm
		4D24TG2-4	28kW/1500rpm
		4D24TG3-4	23kW/1500rpm
		4D24TG4-4	18.5kW/1500rpm
		4D24TG5-4	36kW/1800rpm
		4D24TG6-4	32kW/1800rpm
		4D24TG7-4	28kW/1800rpm
		4D24TG8-4	23kW/1800rpm
4D24TG9-4	18.5kW/1800rpm		
18.	Speed control method	Electro-control	
19.	Fuel system	Electronically controlled vane pump (VP)	
20.	Engine oil consumption rate (g/(kW ·h))	≤0.2	
21.	Emission level	CCS Classification Society Certification / Non-road National IV Certification	
22.	Engine oil capacity (L)	9.5	
23.	Net weight (kg)	260	
24.	Dimensions (L×W×H) (mm)	715×620×681 (with cover)	
25.	Operating temperature range	-10 ~ 40°C (Interior use)	
26.	Seawater pump technical parameters	Flow rate 55L at engine speed 1500rpm, suction height ≤1.5m	

3. Fuel, oil, coolant, and auxiliary materials used in the diesel engine

3.1 Fuel

The quality and composition of fuel are very important. Poor quality fuel will reduce engine performance and durability. To ensure higher reliability and lower fuel consumption of the diesel engine, diesel fuel is recommended:

Diesel fuel should meet the following technical specifications:

1. Must comply with the national standards or international standards of the country of use;

For more details on fuel standards, please refer to the technical specifications of the relevant country;

The user must select different grades of clean diesel according to the ambient temperature of the usage environment, as follows:

Table 3-1

Diesel grade	Operating temperature
0# diesel	Above 4°C
-10# diesel	Above -5°C
-20 Light Diesel Oil	Above -14°C
-35 Light Diesel Oil	Above -29°C
-50 Light Diesel Oil	Above -44°C

Warning

Do not mix gasoline, alcohol, or alcohol-gasoline blended fuel with diesel. Otherwise, it may cause an explosion.

△Note

Due to the extremely precise tolerances of the diesel injection system, it is extremely important to maintain clean fuel and free from dirt or water. If the fuel system contains water or dirt, it may severely damage the fuel pump and injectors. Raywin Powertrain Technology Co., Ltd. requires users to use regular fuel.

3.2 Engine Oil

The parts of the 4D24TG-4 series diesel engine have high precision, therefore, the selection of engine oil also has high requirements. It is necessary to use diesel engine oil of CF-4 grade or higher. It is recommended to use CF-4 grade, viscosity grade 15W-40 dedicated engine oil.

When selecting engine oil, you should choose the appropriate grade of engine oil according to the local season and temperature. And pay close attention to two indicators, namely the engine oil quality grade (performance grade) and viscosity grade. The selection is referred to in the table below:

Table 3-2

Common Quality Grades	CF-4	CH-4	CI-4	CI-4+	CJ
Applicable emission stage	China III Euro III and below	China III Euro III and below	Non-road Euro V		

Table 3-3

Type	Mineral oil type					Synthetic oil type	
Viscosity grade	30	20W-50	15W-50	10W-40	5W-50	5W-50	10W-40
	40	20W-40	15W-40	10W-30	5W-30	5W-30	10W-30
Suitable operating temperature	10 ~ 50	-15~30	-20 ~ 50	-25 ~ 30	-30 ~ 30	-35 ~ 40	-30 ~ 40

This diesel engine requires normal operating oil pressure of (0.3 to 0.6) MPa, and should not be less than during idling operation 0. 1MPa.

Ruiwei Engine (Chongqing) Co., Ltd. diesel engines require multi-grade viscosity engine oil because multi-grade engine oil has a wider suitable temperature working range. This means that in areas with large temperature differences between morning and evening, when the diesel engine's operating temperature varies significantly, or when the diesel engine needs to operate across different temperature regions, as well as over longer seasonal periods, the viscosity of the engine oil can still meet the normal operating needs of the diesel engine. Another important factor is that the consumption rate of single-grade engine oil is about 30% higher than that of multi-grade engine oil.

The grade of engine oil represents the level of additives in the oil. For heavy-duty diesel engines, the main protective function is provided by the additives in the engine oil. Since additives gradually deplete over time, it is necessary to choose engine oil of sufficient grade to ensure that the diesel engine receives reliable protection throughout the entire oil change cycle.

After replacing parts in the 4D24TG-4 series diesel engine, add engine oil as appropriate. After the diesel engine is filled with oil and runs for 2 minutes, let it stand still for 15 minutes, and then check the oil level in the crankcase. The oil level should be between the midpoint between the bottom and top markings on the dipstick and the top marking. (Maximum crankcase capacity: 9.5L)

It is recommended to use the dedicated engine oil specified by Raywin Engine (Chongqing) Co., Ltd. or engine oil that meets or exceeds National IV emission standards. The following dedicated engine oil is recommended for this model:

Table 3-5

Product Name	Model	Packaging Specifications	Scope of Application
Tiger Special Oil	CF-4/SL		Suitable for use in Euro III emission diesel engines.
	10W-30	4L	
	CF-4/SL	16L	
	15W-40	18L	
	CF-4/SL	170Kg	
	20W-50		

Note: Higher grade oil can be used to replace lower grade oil, and the oil-fuel ratio complies with the relevant national or international standards.

Other criteria:

- The engine oil must be replaced when the total base number (TBN) drops to 1.0.
TBN (mgKOH/g), test method: JIS K-2501-5.2-2 (HCl), or ASTM D4739 (HCl);
- The standard engine oil maintenance interval is 250 hours or 12 months;
- Do not add any additives to the engine oil;
- Do not mix different types (brands) of engine oil;

3.3 Antifreeze



Note

When the temperature drops below 0°C in winter, and without insulation measures, the water in the cooling system of a diesel engine will freeze into ice. When water turns into ice, it expands in volume, which can cause the cooling system components such as the engine block, radiator, cylinder head, and water pump to crack. Therefore, it is essential to add antifreeze to the cooling system.

To extend the service life of the diesel engine, it is recommended to use the dedicated antifreeze specified by Raywin Engine (Chongqing) Co., Ltd.

Note: Fresh water is not suitable as engine coolant because its thermal conductivity is very poor, which can lead to insufficient cooling and damage to internal engine components;

Water quality required for preparing engine coolant:

When conditions permit, please purchase the antifreeze specified by Renvi Engine (Chongqing) Co., Ltd. If the corresponding antifreeze cannot be purchased, it is permissible to mix ethylene glycol and soft water that meets the above table. The relationship between the boiling point and freezing point of this type of antifreeze is as follows in the table:

Boiling point and cloud point		
Ethylene glycol volume ratio	Cloud point	Boiling point
	°C	°C
40	-24	106
50	-35	108
60	-52	111

Note: Pressurizing the cooling system can raise its boiling point; the radiator pressure cap can help maintain system pressure; to ensure good water quality, it is recommended to use antifreeze brands and specifications specified by Runway or internationally renowned brands;

3.3.1 Products and Selection Table for Antifreeze Specified by Raywin

Table 3-6

Brand	Model	Packaging Specifications	Freezing point	Minimum applicable Ambient temperature
	YCF4—8	4kg	-8°C	2
	YCF4—25		-25°C	-15
	YCF4—30		-30°C	-20
	YCF4—35		-35°C	-25
	YCF4—40		-40°C	-30
	YCF4—45		-45°C	-35
	YCF9—8		-8°C	2
	YCF9—25	9kg	-25°C	-15
	YCF9—30		-30°C	-20

Tiger Shark	YCF9—35		-35°C	-25
	YCF9—40		-40°C	-30
	YCF9—45		-45°C	-35
	YCF10—8	10kg	-8°C	2
	YCF10—25		-25°C	-15
	YCF10—30		-30°C	-20
	YCF10—35		-35°C	-25
	YCF10—40		-40°C	-30
	YCF10—45		-45°C	-35
	YCF18—8	18kg	-8°C	2
	YCF18—25		-25°C	-15
	YCF18—30		-30°C	-20
	YCF18—35		-35°C	-25
	YCF18—40		-40°C	-30
	YCF18—45		-45°C	-35
	YCF200—8	200kg	-8°C	2
	YCF200—25		-25°C	-15
	YCF200—30		-30°C	-20
	YCF200—35		-35°C	-25
	YCF200—40		-40°C	-30
	YCF200—45		-45°C	-35

Generally, antifreeze should be selected with a freezing point about 10°C lower than the minimum temperature in the diesel engine operating area. For example: If the minimum temperature in Beijing is assumed to be -15°C, then choose antifreeze with a grade of -25.

3.3.2 Precautions for using antifreeze

a. Before adding antifreeze, use clean water to flush the diesel engine cooling system; if possible, use softened water or deionized water for flushing;

b. Pay attention to checking the antifreeze fluid level and the sealing of the cooling system. For diesel engines without a surge tank, do not fill to the top; add about 95% of the volume. For diesel engines with a surge tank, first fill to the specified mark, start the diesel engine for a few minutes, and then continue adding antifreeze to the required level;

c. Antifreeze for different manufacturers and types of diesel engines should not be mixed; otherwise, the performance of the antifreeze will be reduced, and it may even lead to damage to the diesel engine;

d. If the liquid level is below the specified mark, it needs to be replenished to the specified level. The antifreeze added must be of the same manufacturer and brand;

e. Ethylene glycol is toxic; if it comes into contact with the skin, it should be rinsed off immediately with water. Ethylene glycol will burn when exposed to fire, so welding or open flames should never be used near the vehicle if the antifreeze is leaking. Ethylene glycol has a boiling point of 197.4°C, so the water in the antifreeze is prone to evaporation, and water should be added after use for a certain period of time.

3.3.3 Regular replacement of antifreeze

a. Light-duty antifreeze/inorganic salt type antifreeze, replacement cycle is 24 months.

b. Heavy-duty antifreeze/organic acid type antifreeze, replacement cycle is 36 months.

c. Technical requirements for light-duty antifreeze/inorganic salt type antifreeze and technical requirements for heavy-duty antifreeze/organic acid type antifreeze must meet relevant standards of the petrochemical industry or the requirements of Runway Engine (Chongqing) Co., Ltd.'s "Technical Conditions for Q/YC 908 Diesel Engine Cooling Fluid."

3.4 Selection of Storage Battery

In winter, especially in high-altitude, cold, and frigid regions (below -15°C), the discharge capacity of the battery decreases significantly. To ensure and improve the cold-start performance of the diesel engine, low-temperature type batteries of the same capacity should be used or replaced. Examples for selection are shown in the following table:

Table 3-7

General Area Use		High Plateau and Cold Regions Use	
Battery Capacity (Ah)	Cold start current (A)	Battery capacity (Ah)	Cold start current (A)
≥ 120 (165)	570	≥ 180 (195)	622
Note	High-altitude areas (frequent starting, high power consumption), it is recommended to choose the battery capacity in parentheses.		

4. Installation, Operation, and Maintenance of the Diesel Engine

4.1 Operation of the Diesel Engine

4.1.1 Before Starting

a. Check the oil level in the crankcase, ensure there is sufficient oil for lubrication. If it is not enough, add oil to the level indicated by the oil dipstick. When adding oil, check that the oil grade is suitable for the ambient temperature.

b. Check the coolant in the tank to ensure proper cooling; when adding coolant, check that it is suitable for the ambient temperature).

c. Check for air in the fuel lines and water in the diesel filter; inspect if the fuel lines are kinked. Strictly prohibit blocking the return fuel line, as this may cause excessive pressure in the lines, leading to bursting.

d. Check the fuel tank; if it is not full, add fuel. When adding fuel, check that it is suitable for the ambient temperature.

e. Check the electrical system (whether all connection lines and switch wirings are secure and reliable, whether the battery electrolyte is sufficient, and if not, add enough electrolyte).

f. Check the belt, the tension should be appropriate. If the belt is too loose, it will slip, causing the water pump and fan to work abnormally, poor cooling effect, high engine water temperature. If it is too tight, it will exert excessive force on the pulley shaft and shorten the belt life.

H. The marine diesel engine needs to check the inner and outer circulating cooling water conditions:

1. Whether the water-cooled exhaust pipe and heat exchanger water tank are filled;
2. Whether the water-cooled exhaust pipe and heat exchanger water tank are filled;
3. Marine engines are generally equipped with unshielded air filters. Check for foreign objects on the air filter before starting.;

4.1.2 Starting

Do not operate diesel engines in environments where flammable gases are present or could potentially be present, as these gases may be inhaled by the engine through the intake system, causing the engine to accelerate and over-speed. This can lead to fire, explosion, or property damage. Remember that the diesel engine manufacturer cannot know how you operate the diesel engine. Diesel engine users and operators are fully responsible for safely operating diesel engines in harsh environments.

△ Note

Only after completing the pre-start preparations and confirming they meet requirements can the diesel engine be started (preheating is required in cold winter weather before starting), the duration of continuous starting cannot exceed 10 seconds; the interval between secondary starts should not be less than

1 minute; if the engine fails to start three times in a row, check the cause, eliminate the fault, and then start again.



Check oil pressure after startup: At idle speed, it must not be below 0.1 Mpa. If the low oil pressure warning light does not go out within 15 seconds or the dashboard displays no oil pressure, shut down immediately to prevent damage to the diesel engine.

Check if the water pump is working properly, confirm that the cooling fluid has entered the diesel engine's water jacket circulation; no "three leaks," abnormal noises; the condition of all instruments. If any abnormal conditions are found, the vehicle must be stopped immediately for inspection and rectification, and repair is necessary if required.

Cold start: In cooler environments, the starting operation is the same as usual. If preheating is required during starting, wait until the preheating indicator flashes or turns off before starting.

Starting steps after long-term shutdown or oil change

Follow the normal starting steps in this section. If the ECU detects that the oil pressure has not yet reached the minimum starting motor oil pressure, the diesel engine will not start. Starting the diesel engine after long-term shutdown or oil change will require a longer time.

4.1.3 Operation

After the diesel engine starts, run the diesel engine at idle speed and medium speed to warm it up in sequence. It is only allowed to operate at full load and high speed when the coolant temperature is above 60°C and the oil temperature is above 45°C. Pay attention to the following points:



Do not idle for too long, as prolonged idling may reduce the performance of the diesel engine. The oil pressure during idling must not be below 0.1 MPa.

During diesel engine operation, frequently monitor the instrument readings to ensure that oil pressure, oil temperature, and cooling water temperature are within the normal range.

If any instrument alarms, unusual noises, or abnormal vibrations are detected in the diesel engine, stop the engine as soon as possible under safe conditions for inspection.

Pay attention to the sealing of oil, gas, and water. If any leaks are found, they should be eliminated immediately.



New diesel engines or diesel engines after major overhauls are not allowed to operate at high speed and heavy load initially. Within the first 40 hours, power should be reduced and the load should not exceed 65% to ensure proper break-in.

4.1.4 Parking

Diesel engines should be avoided from sudden shutdown due to rapid idling. Before parking, the engine should be operated at low speed for 3 to 5 minutes to allow it to cool down, then idle for 2 to 3 minutes to ensure sufficient lubrication in all parts, and then shut down.

Additionally, attention should be paid to the fact that when the ambient temperature is below 5°C, if the engine coolant cannot be guaranteed not to freeze, the coolant should be drained promptly to prevent damage to the components from freezing.

When the temperature drops below -30°C, the battery should be removed and placed in a warm room for insulation, otherwise it will be difficult to start

4.1.5 Daily Operation Precautions

Compared to traditional mechanical fuel systems, the electronic pump system has stricter requirements for fuel cleanliness.

Only regular clean fuel should be added.

Do not allow the annotated fuel to be contaminated.

When disassembling or assembling the fuel line, it is necessary to keep hands and tools clean to avoid contamination of the fuel line.

The diesel engine fault indicator is located on the control panel. In normal operation, the fault indicator should flash once when the engine is powered on and then remain off. When the diesel engine electronic control system detects a fault, the fault indicator will light up and display the corresponding fault warning. First, turn off the ignition switch, and carefully inspect the engine's fuel, air, and electrical circuits to check for obvious oil leaks, air leaks, or disconnected wire harness connectors.

The general principle is that when the warning light comes on, if the user checks the diesel engine and finds obvious oil circuit, air circuit, or electrical circuit faults, the user can resolve it themselves.

4.1.6 Replenishing Method After Fuel Suction

When the fuel in the fuel line is suctioned out, or when it is necessary to replace the fuel filter, pre-filter, fuel line, etc., air must be completely exhausted from the oil circuit. The steps and precautions for emptying are as follows:

Loosen the vent plug at the top of the fuel filter and empty it with a hand pump until the fuel filter is full of fuel and no bubbles are escaping, then retighten the vent plug;

Loosen the return line of the high-pressure fuel pump and bleed it with the hand pump until the high-pressure fuel pump is filled with fuel and no bubbles are visible, then retighten the vent plug;

Loosen the connections of the high-pressure fuel lines to the fuel injectors of each cylinder and bleed the air from the high-pressure fuel lines with the hand pump until fuel flows out, then retighten the connections;

After completing the bleeding, the fuel flowing out on the diesel engine and the frame must be wiped clean before starting the diesel engine;

During the bleeding process, avoid fuel splashing onto the exhaust pipe, starter motor, or wiring harness (especially connectors). If fuel accidentally splashes, it must be wiped clean.

During the draining process, it must be ensured that the fuel remains clean and free from contamination.

4.2 Use and Regular Maintenance of Land-Based Diesel Engines

- The diesel engine must be serviced promptly for the first time according to the requirements in the user warranty manual and record the maintenance status;

- During operation, the diesel engine should also be routinely maintained according to the following requirements, with daily maintenance performed by the user, while other levels of maintenance are carried out by professional maintenance personnel;

- The air filter is a key component that ensures the diesel engine draws in clean air. It is necessary to frequently check the sealing condition of the intake system and maintain or replace the air filter to ensure the diesel engine does not experience early wear.

4.2.1 Engine Break-in

A new diesel engine requires a break-in period (the first 50 hours) to further improve the matching performance of various moving parts, ensuring the working reliability and service life of the diesel engine. During the break-in period, the following points should be noted:

(1) After starting, the diesel engine must run at a medium or low speed to warm up for at least 5 minutes.

(2) After starting, the load should not be increased abruptly; it must be increased gradually.

(3) The diesel engine should not be idled or run at full load for more than 5 minutes.

(4) Frequently check the oil pressure gauge and water temperature gauge to ensure the diesel engine is operating normally.

For newly overhauled diesel engines, a break-in period is also required (which can be referenced from the break-in of new engines) to ensure the proper fit of all friction pairs. After the break-in period, the engine oil should be changed, and the oil filter element should be replaced. Idling during break-in will cause premature wear.

4.2.2 Maintenance and Care of Diesel Engines

Proper, timely, and meticulous maintenance and care can ensure the long-term good performance of the diesel engine, prevent failures, reduce wear, and extend its service life. Users should perform maintenance and care on the diesel engine according to the content listed in this section, with specific classifications as follows:

4.2.2.1 Maintenance intervals shall be in accordance with the following table

Note: If the operating conditions are severe (minimum temperature below -20°C, or maximum temperature above 35°C, or in dusty environments such as deserts, mining areas, construction sites, coal yards, etc.), the oil change interval should be shortened.

item	Maintenance intervals											
	50hrs	100hrs	250hrs	400hrs	500hrs	1 or 2 months	3 months	800hrs	1500hrs	3000hrs	2 years	
Check the fuel line connections and drain the water from the diesel	☆											
※Oil change	★ first		☆									
Check position of battery electrolyte		☆										
Check fan belt tension and damage		☆										
Check radiator hose and hose clamp		☆										
※Change oil filter	★ first		☆									
Check the intake line			☆									
Change fuel filter			☆									
Clean core of air filter			☆									
Clean inner of fuel tank					☆							
Replace fan belt								☆				
Recharge battery		☆				☆						
Change core of air filter					☆							
Check valve clearance								☆				
※Check injector									☆			
Check turbocharger(if have)										☆		
Replace intake tube system												☆
Replace battery												☆
Replace radiator hose and hose clamp												☆
Replace fuel hose and clamp												☆
Replace radiator coolant(LLC)												☆
Inspecting the seawater pump impeller (marine)					☆							
Replacement of seawater pump impeller (marine)												
Replacement of zinc rods (for boats)											☆	
Clean inside the water jacket and the												☆

Note: After running 50 hours, please change oil and oil filter

According U.S. EPA off road emission standard, above items listed as the important items by our company

4.3 Use and regular maintenance of marine diesel engines

4.3.1 Marine Diesel Engine Heat Exchange System

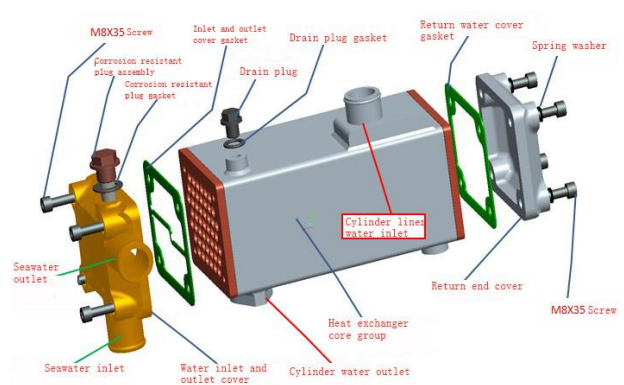
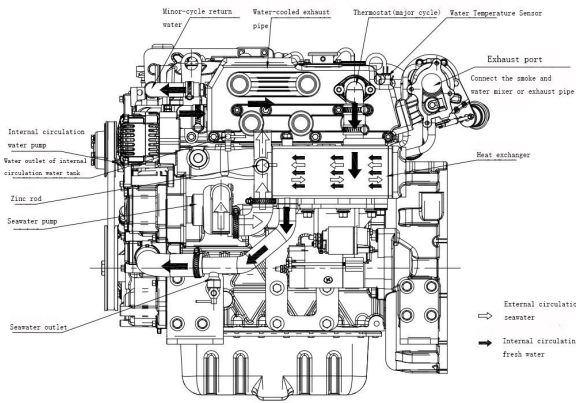

The heat exchanger core assembly

is of tube plate structure. Seawater, under pressure from the seawater pump, flows at high speed inside the heat exchanger's cooling tubes. Engine coolant, after passing through the cylinder block, cylinder head, and water-cooled header pipes, enters the heat exchanger. It flows along the flow guides outside the radiator tubes, transferring heat to cool the cylinder jacket water. Zinc anodes are installed on the end caps to slow down the corrosion of seawater on the heat exchanger components. After a period of use, a layer of scale will form on the surface of the zinc anodes, which should be cleaned regularly; otherwise, they will lose their corrosion protection function. When the zinc anodes themselves are corroded, they should be replaced. It is recommended to replace the corrosion-inhibiting zinc anodes every 3 months.

1. Due to the corrosive nature of seawater, it can damage the surface of the protective layer, causing the pipe to corrode and form scale, reducing the seawater flow area and lowering the cooling effect. Therefore, it should be cleaned regularly and frequently. Remove the inlet and outlet end covers of the heat exchanger, take out the cooling core, and immerse it in water containing descaler. Clean the inner diameter of the heat pipes with a non-metallic brush to remove the scale. After 15 minutes, remove the tube bundle and rinse it thoroughly with water. Check the corrosion of the inlet and outlet end covers and zinc anodes. All gaskets/seals must be replaced.

4.3.2 Seawater pump

The seawater pump is equipped with a high flexural performance rubber impeller. Please use and maintain the seawater pump correctly, otherwise it will lead to a decrease in the seawater pump's water pumping capacity or damage.

Maintenance and Maintenance Precautions:

1. The seawater pump cannot run empty, otherwise it will cause serious wear of the impeller or even scrap.
2. Please install a sea water filter at the front of the seawater pump inlet to prevent debris from entering seawater pump, which could damage the pump impeller and the water seal;
3. Regularly replace the impeller to ensure the seawater pump's water-boosting capacity, otherwise

will

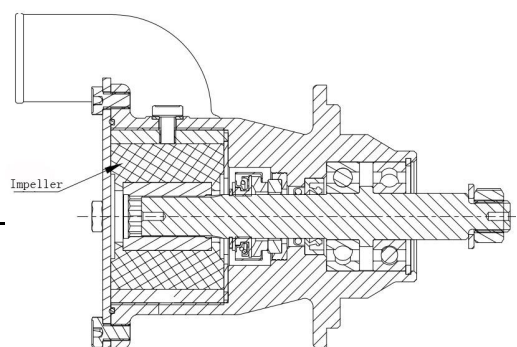
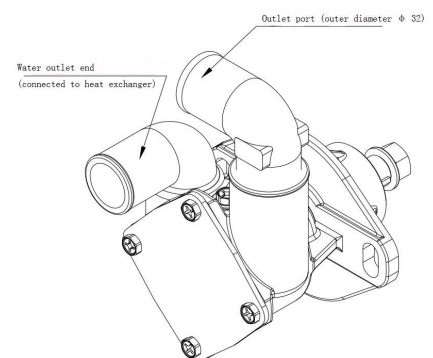

the it

may cause poor engine cooling; when replacing the impeller, first remove the end cover, then use a tool to remove the rubber impeller. Check the impeller every 500 hours and replace it every 800 hours;

4. When the engine is used for a long period, the seawater in the seawater pump and pipeline should be drained, and the remaining water in the internal should be blown dry with compressed air.

4.3.3 Smoke-water mixer (after-vortex cooler)

The smoke-water mixer (after-vortex cooler) is a double-layer structure of corrosion-resistant stainless steel, which can effectively prevent seawater from entering the turbocharger. Do not modify the original structure to avoid damaging the engine.

5. Daily Maintenance and Care Instructions for Diesel Engines

Good maintenance starts with understanding the condition of the diesel engine and its systems every day. Before starting the diesel engine, check the oil level and coolant level, and look for:

- Leaks
- Loose or damaged parts

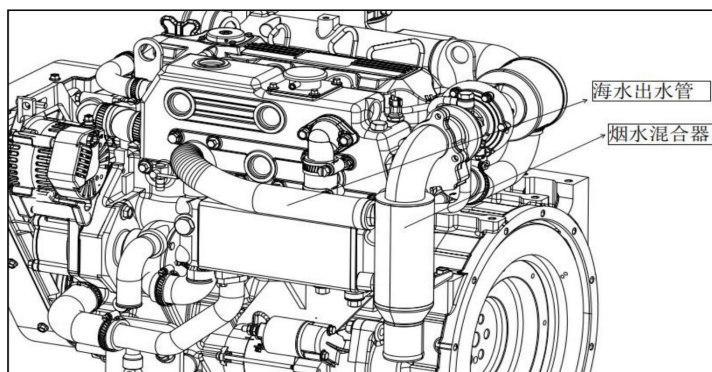

- Is the belt worn or damaged
- Any changes in the appearance of the diesel engine
- Is there a fuel odor

At the same time, it is necessary to check if any warning lights are on. If there are, they need to be investigated. If they are historical faults, they can be cleared.

This section introduces the daily maintenance and upkeep instructions for the diesel engine part systems and components

5.1 Cooling System Coolant Level Check

Coolant Level Check



Warning

Do not open the radiator pressure cap on a hot diesel engine; wait until the coolant temperature drops below 50 °C before opening the cap, otherwise, high-temperature coolant or steam may cause personal injury.



Warning

Coolant is toxic, avoid contact with children and pets. If it is no longer in use, it should be disposed of in accordance with local environmental regulations.

敬告



Warning

Do not use corrosive cleaners in the cooling system, otherwise it will damage the aluminum parts.

△ Note

Do not use sealing additives to solve cooling system leaks. This will cause the cooling system to block and the coolant flow to be poor, leading to overheating of the diesel engine. Must check the coolant level daily.

△ Note

Do not add cold coolant to a hot diesel engine. Otherwise, it will damage the diesel engine castings. Add coolant only after the diesel engine temperature drops below 50 °C.

The additional coolant added to the diesel engine must be mixed with the correct proportion of antifreeze, auxiliary coolant additive, and water to avoid damaging the diesel engine.

Fill the coolant to the bottom of the radiator or expansion tank filling port

5.2 Cooling Fan

The cooling fan should be visually inspected daily. Check for cracks, loose rivets, bent or loose blades. Inspect the fan and ensure it is securely installed. If necessary, tighten the bolts.



Warning

Do not rotate the diesel engine by pulling or prying the fan. Otherwise, it will damage the fan blades, cause fan failure, and result in personal injury or property damage. Use the accessory drive shaft or crankshaft turning tool to rotate the crankshaft.◦



Warning

Do not attempt to straighten bent fan blades or continue using a damaged fan. Bent or damaged fan blades cannot function properly and may cause personal injury or property damage.



5.3 Fuel Filter



Warning

Drain the water from the fuel filter (pre-filter) into a container and dispose of it in accordance with local environmental regulations.

Raywin Powertrain Technology Co., Ltd. requires the installation of fuel filters (pre-filter and fine filter) or oil-water separator in the fuel supply system, and to drain the water and sediment from the fuel filter (pre-filter) or oil-water separator daily.

△ Note

Figure 5-1 Fuel Filter Drainage Diagram

When closing the drain valve, do not tighten the valve too much. Over-tightening may damage the threads.

5.4 Engine Oil Level Check

Check the engine oil level before each start.

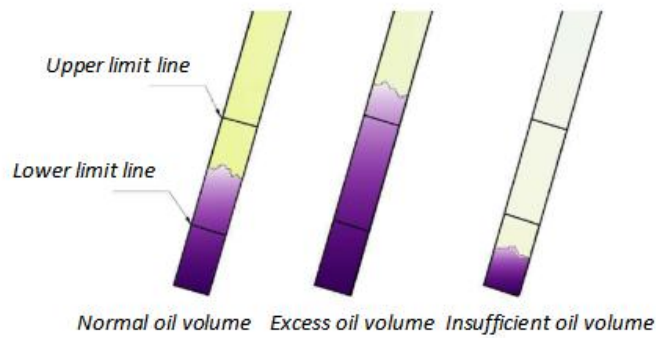

Note

Do not operate the diesel engine when the oil level is below the lower oil level mark or above the upper oil level mark, as this will cause the performance of the diesel engine to decrease and damage the diesel engine.

Figure 5-2 Schematic diagram of oil level for oil filler

The accurate reading can only be obtained when the diesel engine is stopped. At least wait until the diesel engine stops minutes before starting to check the oil level. This time allows the oil to flow back to the oil pan.



Warning

Used engine oil has carcinogenic effects and may cause reproductive diseases. It is recommended to avoid inhaling engine oil vapors, swallowing, and prolonged contact with used engine oil. If it is no longer used, it should be disposed of in accordance with local environmental regulations



Warning

To reduce the possibility of personal injury, direct skin contact with hot engine oil should be avoided.

5.5 Drive Belt Inspection

The tightness of the belt should not be too loose or too tight. Being too loose can reduce transmission efficiency and cause insufficient speed of water pumps, fans, and chargers, affecting cooling effectiveness. At the same time, the vibration generated by being too loose can cause unnecessary wear on belts and pulleys, while being too tight can affect the service life of belts, bearings, and other components.

5.6 Air Filter

Users can determine the blockage status of the air filter by observing the air resistance indicator installed on the intake pipe after the air filter. When the indicator window of the air resistance indicator changes from green to red under normal conditions, it indicates that the air intake resistance of the filter exceeds the specified value, and it should be replaced.



△ Note

Absolutely prohibit diesel engines without air filters or air filters installed Work in the event of device failure. The intake must be pre-filtered to avoid Dust and impurities entering the diesel engine cause early wear.

5.7 Valve Train

To ensure the normal operation of the diesel engine, the user should check and adjust the valve clearance regularly as required. In the cold state, the intake valve clearance is 0.2 ± 0.05 , and the exhaust valve clearance is 0.2 ± 0.05 .

The method for checking and adjusting the valve clearance is:

Rotate the crankshaft to the top dead center position of the first cylinder compression, at this time the 1st, 2nd, 3rd, and 6th valves can be checked and adjusted. Then rotate the crankshaft 360° , at this time the 4th, 5th, 7th, and 8th valves can be checked and adjusted. The valve clearance adjustment can be achieved by adjusting the valves and adjusting screws. When adjusting, first loosen the locking nut, use a screwdriver to turn the valve adjustment screw in or out as needed, then use a feeler gauge to check the clearance between the push-rod and the valve. After it meets the requirements, tighten the locking nut

6. Common trouble of diesel engine and removal methods

Note: This manual describes some typical engine operation problems, the reasons and the solutions.



Warning

Implementation of this chapter of the fault diagnosis and elimination steps may result in machinery damage or personal injury or even death. It must be by trained technicians implement fault diagnosis and troubleshooting work. For not listed in this chapter the diagnosis and exclude steps and symptoms, please contact Raywin.

To make a fault diagnosis, please follow the following recommendations:

- ※Careful analysis of the problem before action;
- ※Start with the most easy and obvious place;
- ※Find the root causes and eliminate the problem。

In order to find fault in time, protect the diesel engine, greatly shorten the maintenance time, improve the utilization efficiency of the diesel engine, RAYWIN 4D24/B, 4D24T/B engine's ECU is with fault diagnosis function. ECU can make diagnose judgment by analyzing electric signals, to diagnose the most electronic components and a few mechanical component failures. Once the fault of electronic control system is detected by ECU, it will produce a corresponding fault code and save the information into ECU memory.

(Stanadyne pump no such steps)

I. Fault indicator

- These fault indicator is located on the dashboard ;
- These are generally red color (for more details please refer to machinery manual);
- These are self-checking after electricity, fault indicator light turns off after 2 seconds ;
- Light turns on once the failure of electrical failure system appears;
- General fault, fault indicator lighting;
- Serious faults, fault indicator flashing;
- Fault disappears, the malfunction indicator light off automatically。

II. fault flash code reading method

Read fault flash code method through fault indicator lamp:

- These are the ignition switch in the ON place;
- with or without load;
- Press diagnose button to activate the fault diagnosis flash code;
- Each operation gets one fault flash code, all fault flash codes can be got one by one;
- Fault flash codes include current and historical code;
- Reading the code after cleaning, which is the current fault code。

For example, using the above method to read ECU memory warning lamp line fault, fault flash code 553, the flashing way of the fault indicator light is as follows:

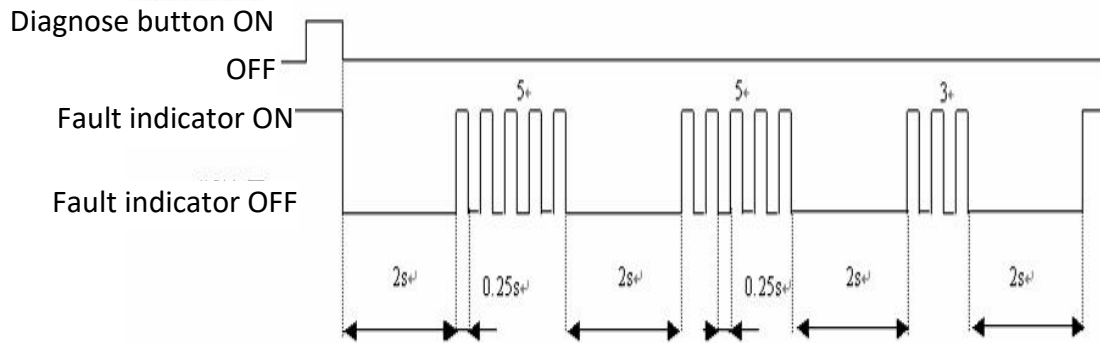

Fault code flash schematic diagram

III. the method of cleaning the historical fault code

In practical application, it can remove the historical fault code in ECU memory conveniently and quickly by using diagnose button, the detail is as follows. :

- Press diagnosis request button;
- Put the ignition button to the OFF place for more than 18 seconds, until ECU power off;
- Put the ignition button to the ON place, ECU power on; ECU power on for 6 seconds (4~8 seconds), then release of the diagnosis request button.

6.1 Diesel engine cannot start

failure cause	Trouble shooting
<p>Fuel quality does not meet the requirements:</p> <ol style="list-style-type: none"> 1. Use incorrect grade of fuel; 2. Excessive fuel impurities; 3. Excessive water in fuel; <p>Qualified to go to step one (Stanadyne pump no such steps)</p>	<p>Replace by qualified fuel, and clean fuel circuit.</p>
<p>Electronic control system cannot power on.</p>	<p>Check wiring harness and fuse, main power switch, especially ignition switch.</p> <p>Method for quickly judging fault :</p> <ol style="list-style-type: none"> 1. Fault indicator light does not light when the power on self-test; 2. The diagnostic instrument cannot be connected; 3. The power line in the throttle connector cannot be 5V voltage

Qualified to go to step two

Battery voltage deficiency.

.....

Replace battery or charge.

Qualified to go to step three

The starter does not work

.....

1. check the switches and wiring is intact, try to use emergency start (continued to press the switch-on request button for more than 5 seconds) to observe starter action.
2. check the start request button, start control relay and its circuit .
3. check whether the shutdown button is in the off status.
4. Check the starter.

**Qualified to go to step four
(Stanadyne pump no such steps)**

ECU memory has the fault code:
1.The fault code can be read through the diagnostic instrument.
2.The fault flash code can be read by the diagnosis request button.
3.The fault information of the electric control system can be read through the CAN meter.

.....

- 1.Check and repair the relevant parts or systems according to the fault code or the fault flash code information, if the fault information from crankshaft/camshaft, then jump to step four.
- 2.After maintenance, use diagnostic instrument or diagnosis request button to delete the historical fault information, and run diesel engine fully, to confirm the ECU memory without fault code information.

**Qualified to go to step five
(Stanadyne pump no such steps)**

Unable to set up work schedule:
1.During the starting, the diagnostic instrument cannot monitor the speed changing;
2.All crankshaft signals are lost
3.Oscilloscope displays timing installation phase error ;

.....

- 1.Check if the crankshaft signal sensor is in good condition;
- 2.Check if crankshaft connector and the conducting wire is intact;
- 3.Check whether the crankshaft signal disc is damaged or not / dirty attachment (through the sensor signal hole)
- 4.Check the gap between crankshaft signal sensor and signal disk installation (generally 1 + 0.5mm);
- 5.If disassemble the signal plate and other components during maintenance, check if the timing phase assembly is correct.

Qualified to go to step six

Low pressure fuel circuit failure

.....

1. Make sure there is enough diesel in the tank;
2. Elimination of air in low pressure fuel circuit;
3. Check the pipes, the joint tightening condition, and , whether the hose and the joint are affected by extrusion, damage, or the diameter is not correct;
4. Check whether the fuel filter, pre-filter are blocked or damaged;
5. Check whether the fuel tank ventilation device is blocked or contaminated (open tank cover and check pumping sound);
6. Check whether the fuel pump and the inlet & outlet of filter are connected incorrectly.
7. Check whether transfer pump is failure.

Qualified to go to step seven

Injector fault

.....

1. Check injector atomizing ;
2. Check injector shim thickness correct or not;
3. Check injector protrusion height correct or not.

Qualified to go to step eight

High-pressure fuel pump failure:
1. Fuel channel blocked in high-pressure fuel pump;
2. High- pressure fuel pump plunger wear;
3. Relief valve of high-pressure pump blocked, contaminated or stuck.

.....

Clean or replace the high-pressure pump, replacement of clean fuel, full road test.

Qualified to go to step nine

Cylinder air tightness and compression performance failure:
1. Insufficient compression pressure.
2. Excessive wear of piston ring.
3. valve leakage.

.....

1. Replace the piston ring, or machining the cylinder hole if necessary;
2. Check sealing of valve clearance, valve spring, valve guide and valve seat, grinding valve seat if sealing is not good;
3. Screw down, clean or replace;

4. Removal of combustion chamber carbon deposition;
5. Check if the crankshaft, connecting rod bending etc..

Qualified to go to step ten

Other mechanical components failure

.....

1. Inspect fuel system/oil system;
2. Inspect intake/exhaust system;
3. Check if the filter is blocked, etc.

6.2 Hard to start

failure cause

Trouble shooting

Insufficient preheat:
1. Under cold conditions, starting before the cold start indicator light flashes off;
2. The battery voltage fluctuation is not normal in the pre-heating process showed on the multimeter or the diagnostic instrument

.....

1. Check whether the preheat circuit wiring is good;
2. Check whether the battery capacity is sufficient.

Qualified to go to step one.

Other reasons

.....

Reference non-start troubleshooting process.

6.3 Diesel engine insufficient power

Failure course

Trouble shooting

Fuel quality does not meet the requirements:
1. Use incorrect grade of fuel;
2. Excessive fuel impurities;
3. Excessive water in fuel;

.....

Replace by qualified fuel, and clean fuel circuit.

Qualified to go to step one (Stanadyne pump no such steps)

Fault code in ECU memory:
1. Fault codes can be read through the diagnostic instrument
2. Fault flash codes can be read through diagnostic request button
3. Electronic control system fault information can be read through

.....

1. If the fault code or fault flash code information clearly points to a specific electronic control components, inspect and repair the corresponding faults of sensors, actuators and its line;
2. After repairs, use the diagnostic instrument or diagnostic request button

CAN meter

to delete the fault historical information, and fully running engine to confirm ECU memory without fault code information.

Qualified to go to step two

Water temperature sensor

.....

1.Check the temperature sensor connector and circuit;
2.Check if the temperature sensor dirty or damaged;

Qualified to go to step three

Low pressure fuel circuit failure

.....

1.Make sure there is enough diesel in the tank;
2.Discharge of air in low pressure fuel circuit;
3.Check the pipes, the joint tightening condition,and, whether the hose and the joint are affected by extrusion, damage, or the diameter is not correct ;
4.Check whether the fuel filter, pre-filter are blocked or damaged;
5.Check whether the fuel tank ventilation device is blocked or contaminated (open tank cover and check pumping sound);
6.Check whether the fuel pump and the inlet & outlet of filter are connected incorrectly.。
7.Check whether transfer pump is failure.

Qualified to go to step four

Intake system block or leakage

.....

Check air filter, air inlet pipe, clean or replace air filter element.

Qualified to go to step five

Exhaust back pressure is too high

.....

Check valve timing and adjust if necessary.

Qualified to go to step six

Turbo system Failure

.....

1. Check and eliminate the leakage from the pipe and connection;
2.Turn the turbocharger shaft to confirm whether turbocharger shaft block or loosen;

3. Check if turbocharger compressor impeller and turbine damaged.

Qualified to go to step seven

Fuel pipeline leakage or block

.....

Check the sealing condition of the fuel pipe and the joint, the blockage of the fuel filter, replace the pre-filter element or fuel filter element when necessary.

Qualified to go to step eight

Diesel engine coolant temperature is too high

.....

Check and repair radiator, thermostat, fan belt tension adjustment.

Qualified to go to step nine

Injector fault

.....

1. Check injector atomizing ;
2. Check injector shim thickness correct or not;
3. Check injector protrusion height correct or not.

Qualified to go to step ten

High-pressure fuel pump failure:
1. Fuel channel blocked in high-pressure fuel pump;
2. High- pressure fuel pump plunger wear;
3. Relief valve of high-pressure pump blocked, contaminated or stuck.

.....

Clean or replace the high-pressure pump, replacement of clean fuel, full road test.

Qualified to go to step eleven

Cylinder air tightness and compression performance failure:
1. Insufficient compression pressure;
2. Excessive wear of piston ring;
3. valve leakage.

.....

1. Replace the piston ring, or machining the cylinder hole if necessary;
2. Check sealing of valve clearance, valve spring, valve guide and valve seat, grinding valve seat if sealing is not good;
3. Screw down, clean or replace;
4. Removal of combustion chamber carbon deposition;
5. Check if the crankshaft, connecting rod bending etc.

Qualified to go to step twelve (Stanadyne pump no such steps)

The control function of the other control module on CAN network and the control function of the diesel engine ECU are interfered		Alternately disconnect other control modules on the CAN network until the communication or function is restored
Qualified to go to step thirteen		
Additional power consumption is too large	Check whether the working cycle time of the cooling fan and the driving device of the diesel engine are working normally.
Qualified to go to step fourteen		
Internal damage of diesel engine	Check and replace damaged parts at the service station

6.4 Abnormal sound during running

Quickly eliminating faults by positioning fault place according to the abnormal sound location. Distinguishing the sound from rotating parts, variation interfered and resonance. Sound of the rotating parts is usually regular, and resonant sound will disappear or strengthen according to speed change.

Failure cause (Stanadyne pump no such steps)		Trouble shooting
Fault code in ECU memory: 1.Fault codes can be read through the diagnostic instrument 2.Fault flash codes can be read through diagnostic request button. 3.Electronic control system fault information can be read through CAN meter	1.If the fault code or fault flash code information clearly points to a specific electronic control components, inspect and repair the corresponding faults of sensors , actuators and its line; 2.After repairs, use the diagnostic instrument or diagnostic request button to delete the fault history information, and fully running engine to confirm ECU memory without fault code information.
Qualified to go to step one		
Crankshaft sensor and its circuit fault	1.Check crankshaft sensor connector and circuit; 2.Check whether installation clearance between crankshaft sensor and the signal panel is installed correctly.; 3.Check whether the crankshaft sensor is dirt or damage。
Qualified to go to step two		
Idle speed abnormal sound	1.Check if there is air in fuel pipes;

2. Check whether injector is normal or not;
3. Fuel filter has a stagnant water cause insufficient fuel supply.

Qualified to go to step three

Abnormal sound during acceleration

.....

1. Check whether air filter is clean, or blocked. Replace the air filter if necessary.
2. Check whether intake and exhaust pipes connected well or leak, air leakage need to be solved.
3. Check whether turbocharger connection pipes are fastened, cleaned, sealed well, or cracked, clean or replace if necessary.
4. Turbocharger bearing broken, rotating parts and housing collide with each other. Turbocharger surge due to too high altitude.

Qualified to go to step four

Mechanical noise / Abnormal sound during acceleration

.....

1. Check timing mark.
2. Check whether the valve timing and valve clearance is correct, adjust if necessary.
3. Check whether the valve spring is abnormal, replace if necessary.
4. Serious wear of camshaft or rocker shaft .
5. Confirm the sealing of cylinder gasket, replace if necessary.
6. Confirm whether the breather and piston ring are working properly, replace if necessary.
7. Piston clearance is too large;
8. Timing mechanism worn.

6.5 Exhaust smoke

Machinery without special engine for plateau works overload on the plateau , it will exhaust black smoke, which is normal phenomenon, and the black smoke will disappear if machinery leaves plateau.

failure cause

Trouble shooting

Fuel quality does not meet the requirements:
1. Use incorrect grade of fuel;

.....

Replace by qualified fuel, and clean fuel circuit

<p>2.Excessive fuel impurities; 3.Excessive water in fuel;</p>	
<p>Qualified to go to step one (Stanadyne fuel pump has no such steps)</p>	
<p>Fault code in ECU memory: 1.Fault codes can be read through the diagnostic apparatus 2.Fault flash codes can be read through diagnostic request switch 3.Electronic control system fault information can be read through CAN meter</p>	<p>1.If the fault code or fault flash code information clearly points to a specific electronic control components, inspect and repair the corresponding faults of sensors , actuators and its line; 2.If read fuel volume slip ring control model related fault codes or fault flash codes information, focus on investigation fuel related failures according to the subsequent steps 3.After repairs, use the diagnostic apparatus or diagnostic request switch to delete the fault history information, and fully running engine to confirm ECU memory without fault code information.</p>
<p>Qualified to go to step two</p>	
<p>Cooling water temperature sensor or circuit fault</p>	<p>Check the cooling water temperature sensor and its circuit, through the diagnostic instrument monitoring the temperature signal value to see if lower than the actual value; dismantle the coolant temperature sensor connector if necessary, and start engine to compare.</p>
<p>Qualified to go to step three</p>	
<p>The resistance of air intake system exceeds technical requirement</p>	<p>Check if the intake system is blocked. If necessary, clean or replace the air filter and the intake manifold.</p>
<p>Qualified to go to step four</p>	
<p>Intake or exhaust leakage</p>	<p>Check whether the air intake system and the exhaust system leak air.</p>
<p>Qualified to go to step five</p>	
<p>Blockage or leakage of radiator</p>	<p>Check if the radiator is blocked or leaked.</p>
<p>Qualified to go to step six</p>	
<p>Exhaust system resistance exceeds technical requirement</p>	<p>Check if the exhaust system is blocked.</p>
<p>Qualified to go to step seven</p>	
<p>Muffler extrusion deformation or blockage</p>	<p>Replace muffler</p>

Qualified to go to step eight	
Injector fault 1.Check injector atomizing ; 2.Check injector shim thickness correct or not; 3.Check injector protrusion height correct or not.
Qualified to go to step nine	
Valve leakage or valve clearance abnormal Check and adjust the valve seal and valve clearance
Qualified to go to step ten	
Insufficient pressure of the turbo system Check and solve the leakage from the pipe and connection.
Qualified to go to step eleven	
Turbocharger operation disorder The turbocharger cannot be rotated or stuck, check and replace turbocharger
Qualified to go to step twelve	
Power consumption is too large Check whether the working cycle time of the cooling fan and the driving device of the diesel engine are working normally.
Qualified to go to step thirteen	
Internal damage of diesel engine Check and replace damaged parts at the service station

6.6 White and blue smoke

White smoke appears sometimes when engine cold start, and water temperature is increased after running for a while, the white smoke will disappear, this is normal phenomenon, not a fault.

failure cause		Trouble shooting
Fuel quality does not meet the requirements: 1.Use incorrect grade of fuel; 2.Excessive fuel impurities; 3.Excessive water in fuel;	Replace by qualified fuel, and clean fuel circuit.
Qualified to go to step one (Stanadyne fuel pump has no such steps)		
Fault code in ECU memory: 1.Fault codes can be read through the diagnostic apparatus 2.Fault flash codes can be read through diagnostic request switch	1.If the fault code or fault flash code information clearly points to a specific electronic control components, inspect and repair the corresponding faults of sensors , actuators and its line;

3. Electronic control system fault information can be read through CAN meter

2. After repairs, use the diagnostic apparatus or diagnostic request switch to delete the fault history information, and fully running engine to confirm ECU memory without fault code information.

Qualified to go to step two

Cooling water temperature sensor or circuit fault

.....

Check the cooling water temperature sensor and its circuit, through the diagnostic instrument monitoring the temperature signal value to see if lower than the actual value; dismantle the coolant temperature sensor connector if necessary, and start engine to compare

Qualified to go to step three

Diesel engines work at lower temperatures

.....

Check the working temperature of the thermostat and replace it if necessary.

Qualified to go to step four

The temperature is too low to start the auxiliary preheat failure

.....

Check whether the preheating plug is able to work properly.

Qualified to go to step five

Low pressure fuel circuit failure

.....

1. Make sure there is enough diesel in the tank;
2. Elimination of air in low pressure fuel circuit;
3. Check the pipes, the joint tightening condition, and , whether the hose and the joint are affected by extrusion, damage, or the diameter is not correct ;
4. Check whether the fuel filter, pre-filter are blocked or damaged;
5. Check whether the fuel tank ventilation device is blocked or contaminated (open tank cover and check pumping sound);
6. Check whether the fuel pump and the inlet & outlet of filter are connected incorrectly.
7. Check whether transfer pump is failure.

Qualified to go to step six

Air filter clogging resulted in an increase in the cylinder intake resistance and poor intake,

.....

Check whether the air filter is blocked.

forming a certain negative pressure, the lubricating oil is absorbed into the combustion chamber.		
Qualified to go to step seven		
Oil level of oil pan is too high	Check whether the oil level of oil pan exceeds the upper limit or not.
Qualified to go to step eight		
Turbocharger seal ring worn	Check and replace.
Qualified to go to step nine		
Turbocharger thrust bearing worn	Check and replace.
Qualified to go to step ten		
Turbocharger oil return line block	Clean, repair
Qualified to go to step eleven		
Injector fault	1.Check injector atomizing ; 2.Check injector shim thickness correct or not; 3.Check injector protrusion height correct or not.
Qualified to go to step twelve		
Valve leakage or abnormal lash	Check and adjust the valve seal and valve clearance.
Qualified to go to step thirteen		
Coolant leaking into the combustion chamber		Check the coolant leaks.
Qualified to go to step fourteen		
Cylinder wall, piston and piston ring wear serious, too large clearance, cause oil sneaked into the combustion chamber and burn	Check condition of cylinder wall, piston and piston ring.
Qualified to go to step fifteen		
Clearance between valve and guide is too large, oil is sucked into the combustion chamber	Replace worn valve and valve guide.
Qualified to go to step sixteen		
Compression pressure is low, the combustion is not complete	Check the piston ring and cylinder gasket.

Qualified to go to step seventeen

Piston ring installation in the wrong direction, openings have not staggered

.....

Check and re-assembly.

Qualified to go to step eighteen

Long-term low-load operation

.....

Pay attention to use appropriate operating speed and load.

Qualified to go to step nineteen

Internal damage of diesel engine

.....

Analysis of the oil and check the oil filter, identify possible damaged parts

6.7 Oil pressure anomaly

**6.7.1 Low oil pressure
Failure cause (Stanadyne fuel pump has no such steps)**

Fault code in ECU memory:
1. Fault codes can be read through the diagnostic apparatus
2. Fault flash codes can be read through diagnostic request switch
3. Electronic control system fault information can be read through CAN meter

.....

Trouble shooting

1. If the fault code or fault flash code information clearly points to a specific electronic control components, inspect and repair the corresponding faults of sensors, actuators and its line;
2. After repairs, use the diagnostic apparatus or diagnostic request switch to delete the fault history information, and fully running engine to confirm ECU memory without fault code information.

Qualified to go to step one

Oil temperature gauge, oil pressure sensor or oil temperature sensor failure, or installed wrong location

.....

Check whether the oil pressure gauge, oil pressure sensor, oil temperature sensor or their circuits work properly, and whether they are in the correct position.

Qualified to go to step two

Lubricating oil thinning or improper use of lubricating oil

.....

Select appropriate lubricating oil according to provisions

Qualified to go to step three

Oil filter regulator failure or improper adjustment

.....

Repair

Qualified to go to step four

Oil filter clogging

.....

Replace oil filter

Qualified to go to step five

Lubricating oil pump inlet pipe crack Qualified to go to step six	Repair or replace.
Fixing bolts of inlet pipe of lubricating oil pump loose Qualified to go to step seven	Tighten to the specified torque.
Rotor of lubricating oil pump wear or too large assembly clearance Qualified to go to step eight	Replace the oil pump.
Bearing clearance is too large	Check and replace

**7.7.2 High oil pressure
Failure cause (Stanadyne fuel
pump has no such steps)**

Fault code in ECU memory: 1.Fault codes can be read through the diagnostic apparatus. 2.Fault flash codes can be read through diagnostic request switch. 3.Electronic control system fault information can be read through CAN meter. Qualified to go to step one	Trouble shooting 1.If the fault code or fault flash code information clearly points to a specific electronic control components, inspect and repair the corresponding faults of sensors , actuators and its line; 2.After repairs, use the diagnostic apparatus or diagnostic request switch to delete the fault history information, and fully running engine to confirm ECU memory without fault code information.
Oil temperature gauge , oil pressure sensor or oil temperature sensor failure, or installed wrong location Qualified to go to step two	Check whether the oil pressure gauge , oil pressure sensor , oil temperature sensor or their circuits work properly, and whether they are in the correct position.
Temperature is too low, oil viscosity increases Qualified to go to step three	Select specified grade lubricating oil, low speed running after start, inspection after oil temperature become normal.
Relief valve blocked	Inspect and clean.

6.8 High oil consumption

Failure cause		Trouble shooting
External lubricating oil pipeline leaks Qualified to go to step one	Check and repair.
Diesel engine overload Qualified to go to step two	1.Reducing the load. 2.Confirm whether the intake system abnormality, diesel engine will cause overload if blocked.
Improper use of lubricating oil Qualified to go to step three	Choose according to regulations.
Dipstick calibrates incorrectly Qualified to go to step four	Check or replace dipstick.
Breather blocked Qualified to go to step five	Replace breather.
Air filter blocked, oil sneak into turbocharger Qualified to go to step six	Check whether the air filter is blocked, confirm the turbocharger shaft rotation is normal rotation without clamping.
Piston ring jammed or wear too much Qualified to go to step seven	Check, repair and replace if necessary.
Cylinder hole worn too much Qualified to go to step eight	Holing and replace piston ring
Valve guide wear too much, valve stem seal failure	Check and replace.

6.9 Cooling water temperature too high (alarm)

Failure cause		Trouble shooting
---------------	--	------------------

Lack of cooling water, the water flow is inappropriate small	Check whether the cooling water is adequate, add if insufficient
Qualified to go to step one		
Whether the belt is too loose	Adjust
Qualified to go to step two		
The water temperature instrument damage, the water temperature induction plug failure.	Check whether the actual temperature is consistent with the temperature indicator; if not, replace the induction plug or water temperature instrument.
Qualified to go to step three		
Expansion tank does not seal well.	Repair in time.
Qualified to go to step four		
water pump leaks.	Repair in time.
Qualified to go to step five		
Thermostat failure, damage.	Check and replace.
Qualified to go to step six		
Punching cylinder gasket.	Check and replace.
Qualified to go to step seven		
Matching problem between radiator and fan under modification condition.	Re-match on request.

6.10 Common failure of turbocharger and its Trouble shooting

Failure cause		Trouble shooting
Intake System blocked	Check the pipes between air filter and compressor, the compressor outlet, intake pipes, and intake manifold. Clean all.
Qualified to go to step one		
Intake leakage	Check leakage of the pipes between air filter and compressor, the pipes between compressor outlet and inlet,

		connection between intake manifold and engine. Tighten bolts, replace gaskets and other parts if necessary
--	--	--

Qualified to go to step two

Exhaust system blocked	Repair or replace related parts
------------------------	-------	---------------------------------

Qualified to go to step three

Exhaust leakage	Check connections of exhaust manifold and diesel engine, inlet of turbo and exhaust manifold, turbo housing and intermediate housing, turbo outlet and exhaust manifold, replace the gasket if leakage, tighten the bolts.
-----------------	-------	--

Qualified to go to step four

Compressor rotor interference with compressor housing body or turbo housing	Replace assembly.
---	-------	-------------------

Qualified to go to step five

Inlet or return oil pipe leakage	Replace.
----------------------------------	-------	----------

6.11 Diesel engine self extinguishing

Failure cause

Fuel quality does not meet the requirements: 1.Use incorrect grade of fuel; 2.Excessive fuel impurities; 3.Excessive water in fuel;	
--	-------	--

Qualified to go to step one (Stanadyne fuel pump has no such steps)

Fault code in ECU memory: 1.Fault codes can be read through the diagnostic apparatus 2.Fault flash codes can be read through diagnostic request switch 3.Electronic control system fault information can be read through CAN meter	
---	-------	--

Trouble shooting

		Replace by qualified fuel, and clean fuel circuit.
--	--	--

		1.If the fault code or fault flash code information clearly points to a specific electronic control components, inspect and repair the corresponding faults of sensors , actuators and its line; 2.If read fuel volume slip ring control model related fault codes or fault flash codes information, focus on
--	--	--

investigation fuel related failures according to the subsequent steps
3.After repairs, use the diagnostic apparatus or diagnostic request switch to delete the fault history information, and fully running engine to confirm ECU memory without fault code information.

Qualified to go to step two

Fuel running out.

.....

Check, add, and remove the air from the fuel circuit.

Qualified to go to step three

Ignition switch circuit failure.

.....

Check the machinery ignition switch circuit.

**Qualified to go to step four
(Stanadyne fuel pump has no such steps)**

Battery power supply to the ECU, voltage too low, interrupt or open circuit.

.....

Check battery terminals, fuses and related circuits.

Qualified to go to step five

Crankshaft sensor and its circuit fault

.....

1.Check crankshaft sensor connector and circuit;
2.Check whether installation clearance between crankshaft sensor and the signal panel is installed correctly.;
33.Check whether the crankshaft sensor is dirt or damage.

Qualified to go to step six

Low pressure fuel circuit failure

.....

1.Make sure there is enough diesel in the tank;
2.Discharge of air in low pressure fuel circuit;
3.Check the pipes, the joint tightening condition,and , whether the hose and the joint are affected by extrusion, damage, or the diameter is not correct ;
4.Check whether the fuel filter, pre-filter are blocked or damaged;
5.Check whether the fuel tank ventilation device is blocked or contaminated (open tank cover and

check pumping sound);
6. Check whether the fuel pump and the inlet & outlet of filter are connected incorrectly.
7. Check whether transfer pump is failure.

Qualified to go to step seven

Injector fault.

.....

1. Check injector atomizing ;
2. Check injector shim thickness correct or not;
3. Check injector protrusion height correct or not.

Qualified to go to step eight

High-pressure fuel pump failure:
1. Fuel channel blocked in high-pressure fuel pump;
2. High- pressure fuel pump plunger wear;
3. Relief valve of high-pressure pump blocked, contaminated or stuck.

.....

Clean or replace the high-pressure pump, replacement of clean fuel, full road test.

Qualified to go to step nine

Diesel engine lubricating oil path is not smooth, cause bearing wear.

.....

If the water temperature is normal and engine sudden stop, Most of such case belong to this situation, should open the oil pan inspection, maintenance, replacement of damaged parts corresponding.

Qualified to go to step ten

Diesel engine overheated and scuffing, generally due to water shortage or water temperature is too high

.....

Let the engine self-cooling (not allowed to fill the cold water or flush with cold water), and then try to rotate the crankshaft, if there is no stuck, can be added with cooling water and then start engine. If crankshaft cannot be rotated regular, engine should be disassembled, inspected, repaired, replaced damaged parts.

**Qualified to go to step eleven
(Stanadyne fuel pump has no such steps)**

Diesel engine ECU failure

.....

Replace ECU.

Qualified to go to step twelve

Internal damage of diesel engine

.....

Check and replace damaged parts at the service station.

6.12 Diesel engine vibration

Failure cause (Stanadyne fuel pump has no such steps)

Fault code in ECU memory:

1. Fault codes can be read through the diagnostic instrument
2. Fault flash codes can be read through diagnostic request button
3. Electronic control system fault information can be read through CAN meter

.....

Trouble shooting

1. If the fault code or fault flash code information clearly points to a specific electronic control components, inspect and repair the corresponding faults of sensors , actuators and its line;
2. After repairs, use the diagnostic instrument or diagnostic request button to delete the fault historical information, and fully running engine to confirm ECU memory without fault code information.

Qualified to go to step one

Ignition switch circuit failure

.....

Check the machinery ignition switch circuit

**Qualified to go to step two
(Stanadyne fuel pump has no such steps)**

Battery power supply to the ECU, voltage abnormal or interrupt

.....

Check whether the battery terminals and related circuits are not in contact

Qualified to go to step three

Crankshaft sensor and its circuit fault

.....

1. Check crankshaft sensor connector and circuit;
2. Check whether installation clearance between crankshaft sensor and the signal panel is installed correctly.
3. Check whether the crankshaft sensor is dirt or damage.

Qualified to go to step four

Low pressure fuel circuit failure

.....

1. Make sure there is enough diesel in

the tank;
2.Elimination of air in low pressure fuel circuit;
3.Check the pipes, the joint tightening condition, and , whether the hose and the joint are affected by extrusion, damage, or the diameter is not correct ;
4.Check whether the fuel filter, pre-filter are blocked or damaged;
5.Check whether the fuel tank ventilation device is blocked or contaminated (open tank cover and check pumping sound);
6.Check whether the fuel pump and the inlet & outlet of filter are connected incorrectly.
7.Check whether transfer pump is failure.

Qualified to go to step five

Injector fault

.....

1.Check injector atomizing ;
2.Check injector shim thickness correct or not;
3.Check injector protrusion height correct or not.

Qualified to go to step six

Pressure temperature sensor or circuit fault

.....

Check the pressure temperature sensor and its line on the intake manifold, and monitor the value of the intake pressure signal by the diagnostic instrument to see whether it is lower than the actual value.

Qualified to go to step seven

Cooling water temperature sensor or circuit fault

.....

Check the cooling water temperature sensor and its circuit, through the diagnostic instrument monitoring the temperature signal value to see if lower than the actual value; dismantle the coolant temperature sensor connector if necessary, and start engine to compare.

Qualified to go to step eight

Engine mounting bolts loose, shock pad damaged, the power

.....

Fastening bolts, replace shock pad, realign.

transmission system is not align.

Qualified to go to step nine

Intake system blockage or leakage.

.....

Check whether the air filter or intake pipes is blocked or leaked.

Qualified to go to step ten

Turbocharger damaged or surge.

.....

Replace the turbocharger, check the working conditions and whether intake pipes are blocked.

Qualified to go to step eleven

Accessories failure.

.....

Check the fan, alternator, belt, bracket, whether interfere or damage, etc.

Qualified to go to step twelve (Stanadyne fuel pump has no such steps)

Diesel engine ECU failure.

.....

Replace ECU.

Qualified to go to step thirteen

Internal damage of diesel engine.

.....

Check and replace damaged parts at the service station.

6.13 Unstable idle speed of diesel engine

(Stanadyne fuel pump has no such steps)

Trouble Shooting

Fault code in ECU memory:
1.Fault codes can be read through the diagnostic instrument
2.Fault flash codes can be read through diagnostic request button
3.Electronic control system fault information can be read through CAN meter

.....

1.If the fault code or fault flash code information clearly points to a specific electronic control components, inspect and repair the corresponding faults of sensors , actuators and its line;
2.After repairs, use the diagnostic instrument or diagnostic request button to delete the fault history information, and fully running engine to confirm ECU memory without fault code information.

Qualified to go to step one

Crankshaft sensor and its circuit fault

.....

1.Check crankshaft sensor connector and circuit;
2.Check whether installation clearance between crankshaft sensor and the signal panel is installed correctly. ;
3.Check whether the crankshaft sensor

is dirt or damage.

Qualified to go to step two

Low pressure fuel circuit failure.

.....

1. Make sure there is enough fuel in the tank;
2. Elimination of air in low pressure fuel circuit;
3. Check the pipes, the joint tightening condition, and , whether the hose and the joint are affected by extrusion, damage, or the diameter is not correct ;
4. Check whether the fuel filter, pre-filter are blocked or damaged;
5. Check whether the fuel tank ventilation device is blocked or contaminated (open tank cover and check pumping sound);
6. Check whether the fuel pump and the inlet & outlet of filter are connected incorrectly.
7. Check whether transfer pump is failure.

Qualified to go to step three

Injector fault

.....

1. Check injector atomizing ;
2. Check injector shim thickness correct or not;
3. Check injector protrusion height correct or not.

Qualified to go to step four

Shock pad damage

.....

Check shock pad.

Qualified to go to step five (Stanadyne fuel pump has no such steps)

Vehicle speed sensor and its circuit fault

.....

Check vehicle speed sensor and its circuit.

Qualified to go to step six

Intake system blockage or leakage

.....

Check whether the air filter or intake pipes is blocked or leaked

Qualified to go to step seven

Valve leakage or abnormal lash

.....

Check and adjust the valve seal and

		valve clearance.
Qualified to go to step eight (Stanadyne fuel pump has no such steps)		
Diesel engine ECU failure	Replace ECU.
Qualified to go to step nine		
Internal damage of diesel engine	Analyze the oil and check the oil filter to determine the potential damage.

6.14 Oil dilution

Failure cause		Trouble shooting
Injector sealing problems	1.Injector mounting hole gland damage cause leakage; 2.Injector leak in the cylinder head
Qualified to go to step one		
Cylinder head crack	Replace.
Qualified to go to step two		
Fuel pump seal not well.	Replace fuel seal .
Qualified to go to step three		
Injector O ring damaged	Check the O ring.

6.15 System lamp / fault lamp is always light (Stanadyne fuel pump has no such steps)

Failure cause		Trouble shooting
Diagnostic request button is turned on	Disconnect the diagnostic request button
Qualified to go to step two		
Fault code in ECU memory: 1.Fault codes can be read through the diagnostic instrument 2.Fault flash codes can be read through diagnostic request button 3.Electronic control system fault information can be read through CAN meter	1.If the fault code or fault flash code information clearly points to a specific electronic control components, inspect and repair the corresponding faults of sensors , actuators and its line; 2.After repairs, use the diagnostic instrument or diagnostic request button to delete the fault history information, and fully running engine to confirm ECU memory without fault code

information.

Raywin Powertrain Technology Co., Ltd

Add: NO.99jiujiang Rd, Shuangfu District, Jiangjin District, Chongqing, China

Tel: +86-23-85553153

Email: info@raywin.cc

Website: <http://www.raywinpower.com>