

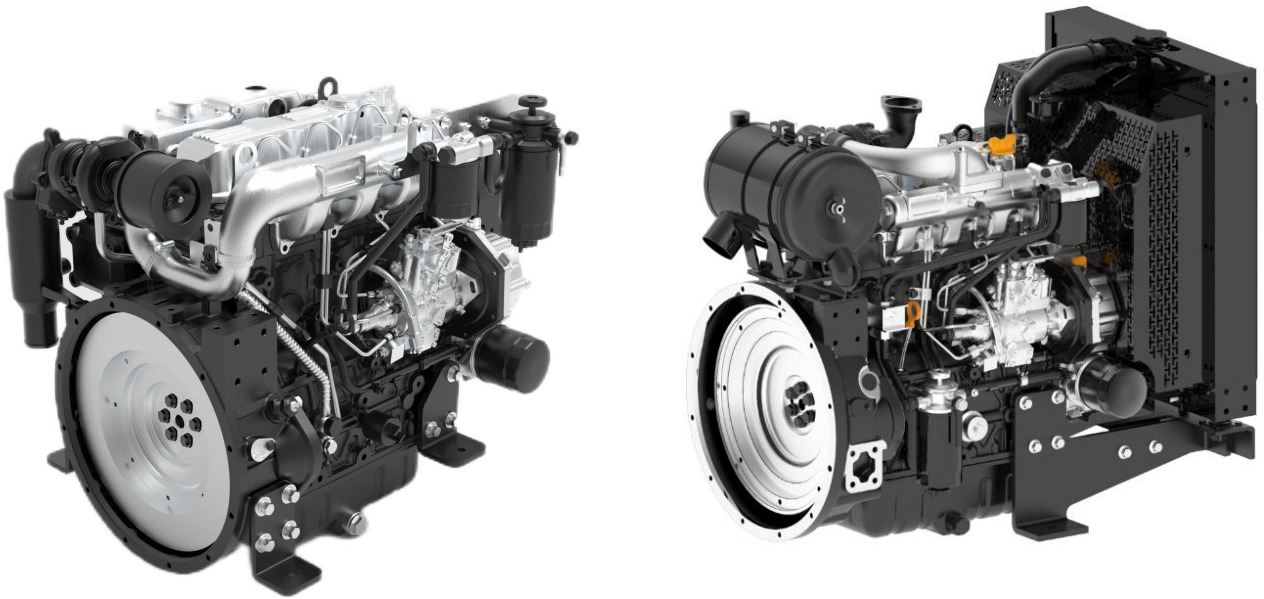

R7100B-4003108SF1

# 4D24/B、4D24T/B Series Diesel Engine Operation & Maintenance Manual

**Please read this manual carefully before using the engine.**



**Raywin Powertrain Technology Co., Ltd.**

March 2024

# Preface

4D24/B & 4D24T/B series off-highway diesel engines are developed by RAYWIN POWERTRAIN TECHNOLOGY CO., LTD. with international engine R&D institutions together. Adopted tunnel block, rotary fuel pump (mechanic or electric governor), turbocharged/naturally aspirated and 2-valve technologies, 4D24/B & 4D24T/B series engines are with reliable, fuel-efficient and strong power characters. It could be applied for agriculture & garden fields, construction equipment, power generation, marine and industrial equipment.

This manual contains some operation and maintenance instructions for 4D24/B & 4D24T/B series diesel engines, and some usual failure removal methods as well. Please know well about the structure, operation and maintenance instruction of this engine. It helps prolong the engine lifetime if the users could make well maintenance.

Further improvement and advancement of product design may causes changes which are not included in this manual.

The interpretation of this manual owned by Raywin Powertrain Technology Co., Ltd.

# CONTENT

1. Foreword .....	1
1.1 General Safety Rules .....	3
2. Overview .....	4
2.1 General Purpose Machinery engine .....	4
2.2 Gensets engine .....	0
2.3 Marine Applications .....	2
2.4 Agriculture & Construction Applications .....	0
3. Installation and sea trials .....	0
4. Fuel, oil, antifreeze and auxiliary battery .....	0
4.1 Fuel .....	0
4.2 Oil .....	0
4.3 Antifreeze .....	2
4.4 Battery selection .....	4
5. Engine Operation & Maintenance .....	4
5.1 Engine Operation .....	4
5.2 Maintenance of diesel engine .....	7
6. Diesel engine daily maintenance instructions .....	2
6.1 Coolant level check of cooling system .....	2
6.2 cooling fan .....	3
6.3 Fuel filter .....	3
6.4 Check oil level .....	3
6.5 Drive belt check .....	4
6.6 Air filter .....	4
6.7 Valve .....	5
7. Common trouble of diesel engine and removal methods .....	5
7.1 Diesel engine cannot start .....	7
7.2 Hard to start .....	10
7.3 Diesel engine insufficient power .....	10
7.4 Abnormal sound during running .....	13
7.5 Exhaust smoke .....	15
7.6 White and blue smoke .....	17
7.7 Oil pressure anomaly .....	20
7.8 High oil consumption .....	22
7.9 Cooling water temperature too high (alarm) .....	23
7.10 Common failure of turbocharger and its Trouble shooting .....	24
7.11 Diesel engine self extinguishing .....	25
7.12 Diesel engine vibration .....	28
7.13 Unstable idle speed of diesel engine .....	30
7.14 Oil dilution .....	32
7.15 System lamp / fault lamp is always light (Stanadyne fuel pump has no such steps) .....	33

# 1. Foreword

The relating statistic data shows:

**80% repairs is made after failure**

Repairs after failure 80%

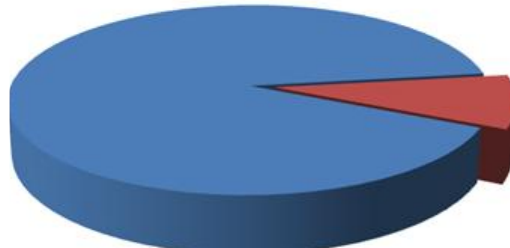

Repairs before failure 20%

**90% repairs is preventable.**

Preventable repairs 90%.

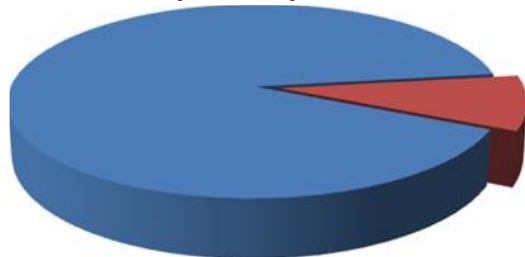

Unpreventable repairs 10%.

**Preventive maintenance is simple and lower cost, please make the maintenance according to the maintenance instructions in this manual, and make regular preventative maintenance records.**

**Please utilize the fuel, oil and coolant correctly as per the instructions in this manual, and do not mix the fuel and oil together for the engines with after-treatment equipment.**

 **Attention**

**When welding on the machinery, please remove the battery positive and negative pole cables from the battery, and dismantle all plugs on the ECU as per the procedure to prevent from ECU damage, do not connect or dismantle ECU plugs with electrification, also do not perform welding operations on the engine or on the engine mounting parts, otherwise the engine or components may be damaged.**

The meaning of the safety alert symbols is listed as follows:



**Warning**

**If do not follow this instruction, it will cause serious personal injury or substantial property damage**

 **Attention**

**If do not follow this instruction, it will cause personal injury or parts, assembly, engine damages.**

Illustration description: Some illustrations in this manual are schematic, it may be different from the engines or parts that you use actually.

## 1.1 General Safety Rules



### Warning

Incorrect procedures, carelessness or neglect of warning instructions may cause burns, cuts, body mutilation, asphyxiation or other injury or even death.

Before maintenance, please read and understand all the security measures instructions and warnings carefully. The following pages contain a general security measures to ensure personal safety that you should follow.

- ◆ Maintenance area should be dry, bright and well ventilation, no sundries, scattered tools, parts, fire and other dangerous items. To pay attention to a dangerous situation may exist.
- ◆ Do not touch rotating parts, because the rotating parts may cause lacerations, physical disability, even death.
- ◆ Do not rotate the crankshaft by leveraging the fan. This approach may cause serious personal injury, property damage, or damage the fan blades, causing premature failure of the fan.
- ◆ If the engine has been running for a while, and the coolant is hot, the engine should be gradually cooled firstly, then loosen the filling port cap slowly to release pressure in the cooling system, or else it could cause scald and other personal injury.
- ◆ Corrosion inhibitor (coolant additives and ingredients in oil) contains alkali. Do not make these substances into the eyes. Avoid skin touch with it time and again. Do not swallow it. In case of contact, please wash the skin with soap immediately. If it enters eyes, please rinse with plenty of water for fifteen minutes at least, and go to hospital at once. Put it where children can not touch.
- ◆ In order to reduce the possibility of burns, do not touch the hot parts, exhaust pipeline, hot liquid and engine cabin while the engine is stopped.
- ◆ When replace the fasteners, please use the fasteners with the same part number (or equivalent). Do not use the poor quality fasteners.
- ◆ Avoid inhalation oil vapors, do not swallow, or contact used oil for a long time.
- ◆ Do not connect starting cable or battery charging cable with any ignition or speed control cable, or else it may cause ignition and governor damage.
- ◆ Please tighten fasteners and fuel connectors according to the technical specifications. It may cause leakage if the fastener or connector is too tight or loose.
- ◆ The smell of leaking fuel will weaken gradually, therefore, test whether there is fuel leakage in accordance with the testing methods as instructions.
- ◆ The coolant is toxic, please make treatment in accordance with relating environmental regulations if you do not continue to use it.

## 2. Overview

### 2.1 General Purpose Machinery engine

#### 2.1.1 Engine schematic diagram

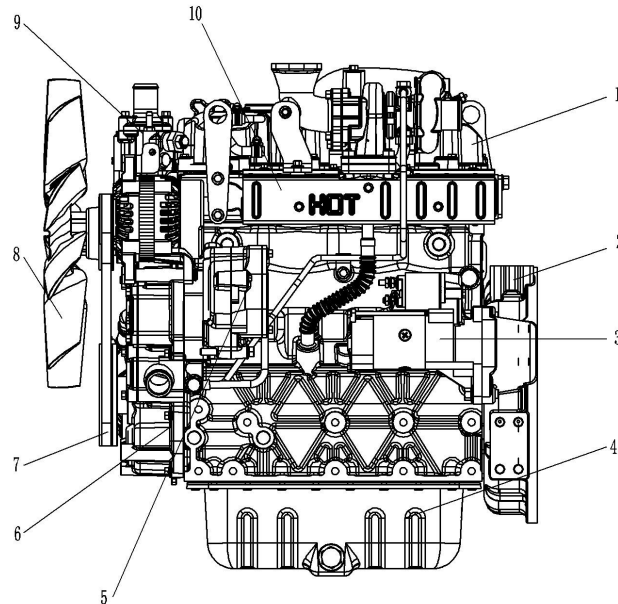

1. Cylinder head cover    2. Flywheel housing    3. Starter    4. Oil pan    5. Side PTO  
6. Timing gear case    7. Belt    8. Fan    9. Thermostat    10. Exhaust manifold and heat shield

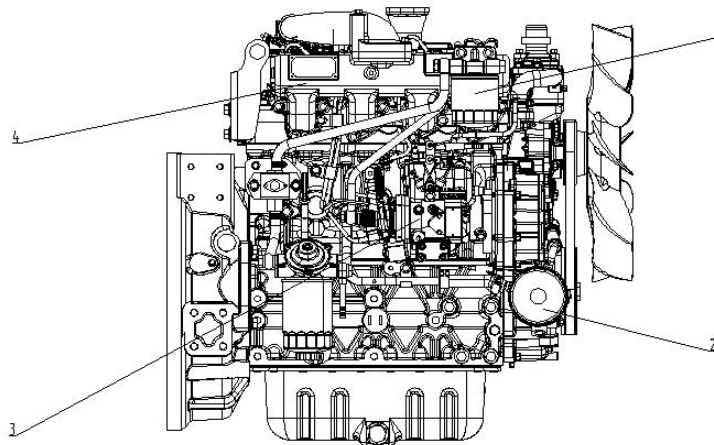

1. Fuel filter    2. Oil filter    3. fuel injection pump    4. Intake manifold

#### 2.1.2 Model characters explanation

**4D24T00/B:**

**4**-----4 cylinders

**D**-----series code

**24**—2.4 liters displacement

**T**----- turbocharged

**00**----- Spectrum code

### 2.1.3 Main Applications and Working Environment

4D24/B & 4D24T/B series diesel engines can be applied for agriculture & garden fields, construction equipment, power generation, marine and industrial equipment.

Engine can work properly with ambient temperature of -30 °C ~ 45 °C, it prohibits from running under the environment of water leaching and fire. When the ambient temperature is below -30 °C or higher than 50 °C or altitude over 2000 meters(1000 meters for 4D24/B naturally aspirated type), please consult with our technology or service department and take effective measures or use the special engine to ensure that the engine could work properly.

### 2.1.4 Engine Data & Specifications

**Table 2-1 4D24/B & 4D24T/B Series Diesel Engine Technical Parameters**

Parameter	4D24/B	4D24T/B
Type	Vertical, Inline, Water cooled, 4-stroke	
Aspiration	Naturally	Turbocharged
Combustion System	Direct Injection	
Cylinder Nos.	4	
Valves Nos. per Cylinder	2	
Bore(mm)	87	
Stroke(mm)	103	
Displacement(L)	2.449	
Compress Ratio	19	17.8
Cylinder Type	Without Cylinder Liner	
Lubrication Mode	Pressure Splashing	
Starting	Electric start	
Cooling	Forced water cooled closed cycle	
Ignition Sequence	1-3-4-2	
Crankshaft rotating direction	Anti-clockwise(face to flywheel)	
Rated Power(kW)	36.8	48
Rated Speed(r/min)	3000	2700
Max. Torque (N·m/rpm)	160 / 1800	210 / 1700
Oil Consumption [g/ (kW·h) ]	≤0.2	
Emission	EU stage III,	
Oil Capacity (L)	9.5L	
N.W (kg)	250(without radiator)	275(without radiator)

## 2.2 Gensets engine

4D24G/B and 4D24TG/B series diesel engines are applied for power generation, covering multiple speed options:1500rpm, 1800rpm and 3000rpm,and wide power range.

### 2.2.1 Model characters explanation

Product model is represented by Arabic numerals and capital letters, its composition is as follows:

4D24TG0/B

4----4 cylinders

D----series code

24—2.4 liters displacement

T---- turbocharged

G---- Gensets application

0----- Spectrum code

### 2.2.2 Layout

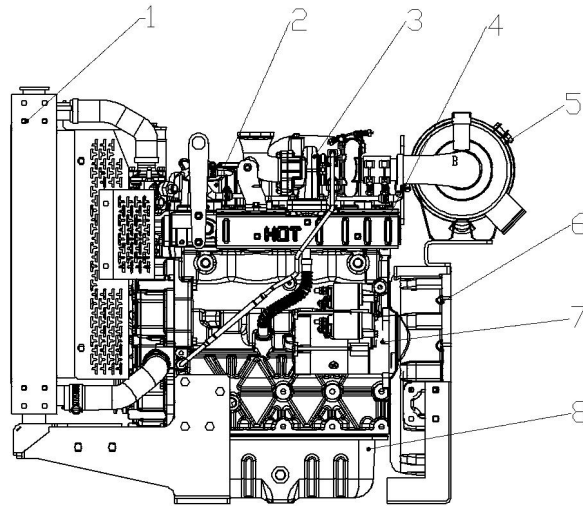

1. Radiator    2. Cylinder head cover    3. Turbocharger    4. Exhaust manifold cover  
5. Air filter    6. Flywheel housing    7. Starter motor    8. Oil pan

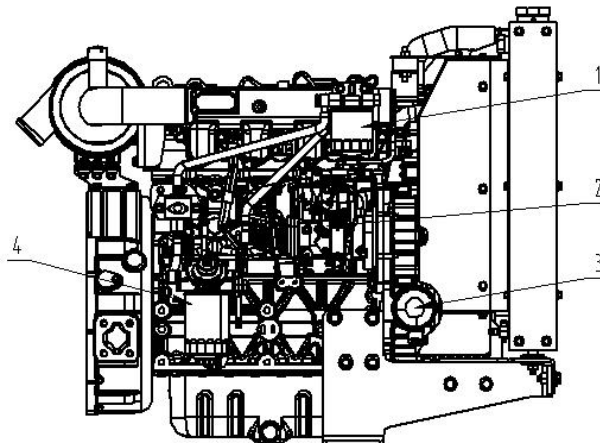

1. Fuel filter    2. Fuel pump    3 Oil filter    4. Fuel Pre-filter

## 2.2.3 Engine Data & Specifications

### Sheet 2—2 4D24G/B series (Naturally aspirated) diesel engine

#### Main Parameter

Model	4D24G0/B	4D24G1/B	4D24G3/B	4D24G2/B	4D24G4/B
Type	Vertical, In-line, Water Cooled, Four Stroke				
Induction System	Naturally Aspirated				
Combustion Chamber	Direct injection				
Cylinder NO.	4				
Bore (mm)	87				
Stroke (mm)	103				
Displacement (L)	2.449				
Prime Power (kW) / Speed (rpm)	33.5 / 3000	27 / 1800	22 / 1800	23 / 1500	18.5 / 1500
Standby Power (kW) / Speed (rpm)	36.8 / 3000	29.7 / 1800	24.2 / 1800	23 / 1500	20.4 / 1500
Min. fuel consumption (g/kW·h)	≤245	≤245	≤242	≤243	≤242
Emission level	EU stage III				
Firing order	1—3—4—2				
Direction of rotation	Anticlockwise(view from flywheel)				
Oil capacity(L)	9.5L				
Start method	Electric start				
Net weight (with radiator) (kg)	270				

### Sheet 2 - 3 4D24TG/B (Turbocharged) series diesel Engine Main Parameter

Model	4D24TG0/B	4D24TG1/B	4D24TG2/B	4D24TG3/B	4D24TG4/B
Type	Vertical, In-line, Water Cooled, Four Stroke				
Induction System	Turbocharged				
Combustion Chamber	Direct injection				
Cylinder NO.	4				
Bore (mm)	87				
Stroke (mm)	103				
Displacement (L)	2.449				
Prime Power (kW)/ Speed (rpm)	36 / 1500	32 / 1500	28 / 1500	36 / 1800	40 / 1800
Standby Power (kW)/Speed (rpm)	39.6 / 1500	35.2 / 1500	30.8 / 1500	39.6 / 1800	44 / 1800
Min. fuel consumption (g/kW·h)	≤245	≤245	≤245	≤245	≤245
Emission level	EU stage III				
Firing order	1—3—4—2				
Direction of rotation	Anticlockwise(view from flywheel)				
Oil capacity(L)	9.5L				
Start method	Electric start				
Net weight (with radiator) (kg)	275(with radiator)				
Dimension (L×W×H) mm	1002*576*813(with radiator)				

## 2.3 Marine Applications

### 2.3.1 Engine schematic diagram

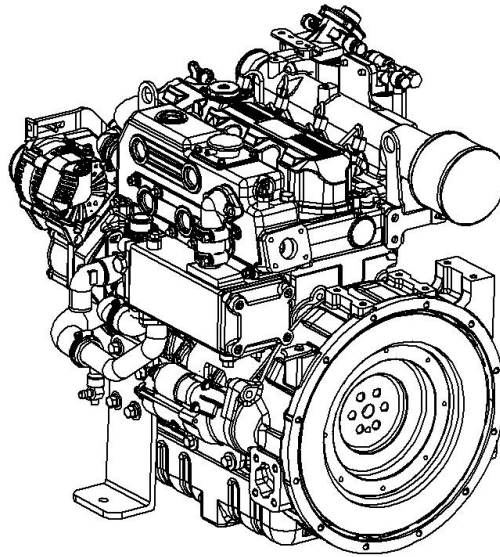

4D24/B series Marine Engine

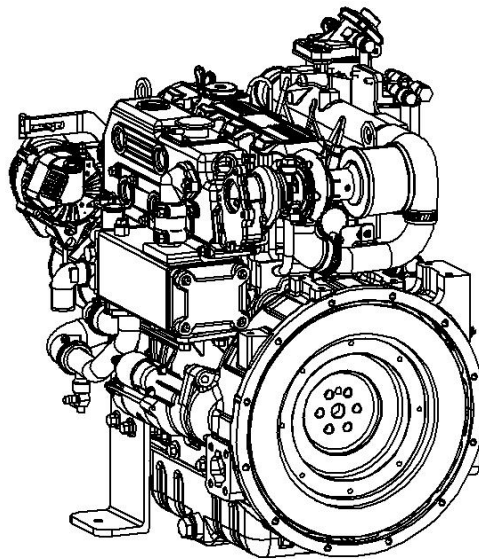

4D24T/B series Marine Engine

### 2.3.2 Model characters explanation

Product model is represented by Arabic numerals and capital letters, its composition is as follows: 4D24TG0/B

4-----4 cylinders

D-----series code

24—2.4 liters displacement

T----- turbocharged

G----- Gensets application

0----- Spectrum code

### 2. 3. 3 Main scope of application

Suitable for environments with temperatures ranging from -30 °C to 45 °C. It is prohibited to work in water immersion or fire environments. When the ambient temperature is below -30 °C or above 45 °C or the altitude exceeds 2000 meters (when the naturally aspirated engine altitude exceeds 1000 meters), users should consult the technical service department of Raywin Powertrain Technology Co., Ltd. to take effective measures or use corresponding specialized diesel engines to ensure that the diesel engine can work normally.

The 4D24/B and 4D24T/B series marine engines are only suitable for marine main and auxiliary engine applications.

### 2. 3. 4 Main parameters for various applications

Sheet 2 - 4 4D24/B、4D24T/B series diesel Engine Main Parameter

S/N	Items	Specifications	
		4D24	4D24T
1	Model	4D24	4D24T
2	Type	Vertical, In-line, Water Cooled, Four Stroke	
3	Induction System	Natural Aspiration	Turbocharged
4	Combustion Chamber	Direct injection	
5	Cylinder NO.	4	
6	Valve NO. per cylinder	2	
7	Bore (mm)	87	
8	Stroke (mm)	103	
9	Displacement (L)	2.449	
10	Compression ratio	19	17.8
11	Cylinder type	Without Cylinder Liner	
12	Lubricating system	Pressure and splash lubrication	
13	Start method	Electronic start	
14	Cooling system	Forced water cooling closed cycle + Seawater pump heat exchange system	
15	Fire order	1-3-4-2	
16	Crank Rotation	CCW(from flywheel)	
17	Standby Power (kW)	Please refer to the Raywin model brochure for each model	
18	Speed (r/min)		
19	Max torque/speed (N.m/rpm)		
20	Oil consumption (g/(kW·h))	≤0.2	
21	Qualification certificate	CCS/ZC	
22	Oil capacity (L)	9.5	
23	Dry weight (kg)	714×620×682 (With	702×596×682 (With
24	Dimensions (L×W×H) (mm)	belt guard)	belt guard)

## 2.4 Agriculture & Construction Applications

4D24/B series and 4D24T/B series diesel engines have been widely applied to agriculture sector, construction sector, marine sector, can supply reliable power for harvester, tractor, picking machine, excavator, boat, yacht and other farm machinery and engineering machinery.

### 2.4.1 Typical application samples



Marine      Gen-set      Light Tower      Air Compressor      Aerialwork Platform      Sweeper



Harvester      Excavator      Loader      Forklift      Tractor      Water Pump

### 2.4.2 Main parameters for various applications

Sheet2 - 5 4D24 ( Naturally aspirated ) series diesel Engine Main Parameter

Parameter \ Application	Agriculture	Construction	Marine	Garden	Air Compressor
Rated Power ( kW )	36.8	29.5	29.5	36.8	33.5
Rated Speed ( r/min )	3000	2000	1800	3000	3000
Max Torque ( N.m )	165	169	150	165	140
Speed of Max. Torque ( r/min )	1400~1600	1600~1800	1600~1800	1400~1600	1400~1600
Torque reserve ( % )	22	20	N/A	N/A	24
Emission level	EU Stage III				
Net weight ( kg )	220	186	205	192	190
Size ( L×W×H ) ( mm )	687×505×708 (for reference only, subject to specific application)				

## Sheet 2 - 6 4D24TG (Turbocharged) series diesel engine main parameter

Applications parameter	Agriculture	Construction	Marine	Garden	Combine
(kW) /Rated Power (r/min)	48	42	36	48	42
Rated Speed (r/min)	2600	2200	1800	2700	2200
Max Torque (N.m)	200~218	210	150	210	210
Speed of Max. Torque (r/min)	1600~1800	1600~1800	1600~1800	1600~1800	1600~1800
Torque reserve (%)	22~25	15	N/A	N/A	N/A
Emission level	EU Stage III				
Net weight (kg)	205	205	205	205	205
Dimension (L×W×H) (mm)	687×505×728 (for reference only, subject to specific application)				

### 3. Installation and sea trials

#### 3.1 Diesel engine installation

##### 3.1.1 Connection of diesel engine, gearbox, and propeller;

1. After the connection between the diesel engine and the gearbox is completed, the diesel engine grade gearbox feet should be locked with pins.

2. Use a plug gauge to check the coaxiality and end face run out of the diesel engine and gearbox. After measurement, use a pin to lock the machine foot.

Note: If the connection between the diesel engine and the gearbox is elastic, the engine feet of the diesel engine and gearbox are supported with elastic damping rubber.

##### 3.1.2 Installation of front-end output terminal

1. The front additional pulley does not allow users to modify it themselves system

2. The belt should be arranged symmetrically

3. The groove of the pulley should be ensured to be in the same plane

4. The maximum allowable radial power of the front-end output pulley and the total power of the front-end power output equipment (including radial output and axial output) must comply with relevant technical regulations.

##### 3.1.3 Check fuel lines

1. Check the height of the fuel tank and filter;

2. Check if the fuel returns to the fuel tank;

Attention:

It is strictly prohibited to block the return pipe and avoid direct short circuiting between the return pipe and the inlet pipe

### **3.1.4 Check the seawater pipeline**

1. The inlet and outlet pipe diameters should not be smaller than those on the diesel engine, and the outlet pipe diameter should be at least one gear larger, and each connection should be as smooth as possible

2. There is a debris filtering device in front of the seawater pump;

3. The gearbox needs to be cooled with seawater from the main engine, and the diesel engine should be cooled first before the gearbox

Cooling water flow direction sequence;

4. In order to prevent insufficient water inflow, resulting in poor intercooling effect or high water temperature, it is strictly prohibited to connect the cooling water pipes in parallel to the Intercooler and the heat exchanger.

### **3.1.5 Check the intake pipeline**

1. Check if the air filter is clean

2. When the cabin temperature cannot be maintained at 25 degrees Celsius, it is recommended that the air intake be extended outside the cabin

3. It is not allowed to use air filters without installation

### **3.1.6 Check exhaust**

1. The entire exhaust should be smooth

2. To check the diameter of the exhaust pipeline

### **3.1.7 Check electrical instruments**

1. Check if the wiring is correct

2. Check if the connectors of each sensor are loose

3. Is there any metal contact at each joint

### **3.1.8 Others**

1. Ship engines are only used for marine main engines and auxiliary engines;

2. The onshore power generation diesel engine is only suitable for supporting onshore generator sets.

## **3.2 Marine diesel engine test**

### **3.2.1 Check the condition of internal and external circulating cooling**

#### **water, engine oil, and diesel fuel**

1. Is the heat exchanger water tank filled up

2. Is there any leakage in the pipeline of the external circulation seawater pump and the

seawater outlet flow after starting

3. Is there enough oil pan
4. Is there sufficient fuel in the fuel tank and air in the pipelines

### **3.2.2 Check electrical instruments**

1. Check whether the oil pressure, oil temperature, water temperature and Tachometer display are normal
2. Whether the pipeline connection is correct and whether the joints are loose

### **3.2.3 Check the intake and exhaust pipelines on the ship**

1. Check for air leakage in the pipeline

### **3.2.4 Check the maximum idle speed**

Auxiliary equipment (with unit): set and check according to the rated speed at full load, and it is not allowed to be lower than the rated speed;

Main engine: Check the idle speed, which should be between 1.08 and 1.13 times the rated power speed.

## 4. Fuel, oil, antifreeze and auxiliary battery

### 4.1 Fuel

Fuel quality and composition is very important. Poor quality fuel reduces engine performance and durability

In order to make the diesel engine has higher reliability and lower fuel consumption, we recommend using the diesel complied with relating national standard or international standard.

For more details of the fuel standards, please refer to the technical specifications of the respective country.

Users must select suitable diesel at different ambient temperature as follows:

Table 3- 1

Diesel Grade	Ambient Temperature
0#	Above 4°C
-10#	Above -5°C
-20#	Above -14°C
-35#	Above -29°C
-50#	Above -44°C



#### Warning

Do not mix gasoline, alcohol or alcohol-gasoline mixture in diesel, otherwise it will cause explosion.



#### Attention

**Because the tolerance of diesel injection system is extremely precise, it's very important to keep the fuel clean and no dirt or water. If there is water or dirt in the fuel system, it may severely damage the fuel pump and injectors.**

RAYWIN requires the user to use recommended fuel.

### 4.2 Oil

The precision of 4D24/B series engine parts is very high, hence the oil selection requirements is strict. Above CF-4 level engine oil must be used, engine oil CF4 15W-40 (quality grade of CF-4, viscosity grade of 15W-40) is recommended.

The oil with suitable grade should be selected according to the local season and temperature, and must pay attention to two indicators, namely the oil quality level (Performance Level) and viscosity grade as below:

**Table 3-2**

Grade	CF-4	CH-4	CI-4	CI-4+	CJ
Available emission level	EU stageIII ,	EU stageIII ,	EU stageIII,		

**Table 3-3**

Type	Mineral oil type					Synthetic oil type	
viscosity grade	30	20W-50	15W-50	10W-40	5W-50	5W-50	10W-40
	40	20W-40	15W-40	10W-30	5W-30	5W-30	10W-30
Available ambient temperature °C	10~50	-15~30	-20~50	-25~30	-30~30	-35~40	-30~40

Oil pressure of this engine is (0.3 ~ 0.6) MPa at rated speed, and not less than 0.1MPa at idle speed.

RAYWIN engine requires multi-grade viscosity oil, because the suitable temperature operating range of multi-grade viscosity oil is wide, which can meet the requirement of the engine works properly with temperature varied by a wide margin in the morning and evening, or works across different temperature regions, or works during long time season. Furthermore, the consumption of single-grade viscosity oil is about 30 percent higher than the multi-grade viscosity oil.

Oil grade represents the level of engine oil additives, for heavy duty engine, the oil additives is the main protective matters. The additives will be consumed over time gradually, that's why the adequate grade oil should be chosen for ensuring the engine to be well protected throughout the oil change interval.

Please fill the oil according to the circumstances after replacing the oil filter. After filling the oil, run the engine for 2 minutes then make it be still for 15 minutes, check the oil sump level, the oil level should be in the place between 1/2 of lower/upper limit and upper limit.

RAYWIN recommended oil for 4D24/B & 4D24T/B is listed below:

**Table 3-4**

Name	Grade	Package	Available emission level
Hanhu oil	CF-4/SL 10W-30	4L	EU stage III
	CF-4/SL 15W-40	18L	
	CF-4/SL 20W-50	170Kg	

The user can use higher grade oil instead of low grade oil, oil and fuel ratio should be complied with relating national or international standard.

Other rule:

- When the total alkalinity (TBN) of the engine oil drops to 1.0, it must be replaced.

TBN (mgKOH/g) tested standard: as per JIS K-2501-5.2-2 (HCl) , or ASTM D4739(HCl)

- Standard engine oil replacement interval is 250 hours or 12 months.
- Do not add any additives in the engine oil.
- Do not blend different types, and/or brands oil.

### 4.3 Antifreeze

#### △ Attention

**When the engine stops working and no insulation measures is took below 0 °C, the water in the cooling system will freeze, and the volume expands which causes block, radiator, cylinder head, water pump and other cooling system components cracked, therefore, antifreeze must be filled into the cooling system.**

For a longer lifetime, we suggest to use RAYWIN recommended antifreeze.

#### △ Attention

Fresh water is not suitable for the engine coolant, because the thermal conductivity of fresh water is very poor, which can lead to inadequate cooling and make engine internal component damaged.

Water preparation required for engine coolant

When available, please buy the antifreeze specified by RAYWIN POWERTRAIN TECHNOLOGY CO., LTD. If the appropriate antifreeze can not be got, ethylene glycol and soft water are allowed to be blended, and the relationship of the boiling point and pour point of this antifreeze is listed below:

Boiling point and pour point		
Glycol and soft water volume ratio	Boiling point	Pour point
	°C	°C
40	-24	106
50	-35	108
60	-52	111

Pressurized cooling system can increase its boiling point, radiator pressure cap can help keep the system pressure, in order to ensure good water quality, we recommend using our specified or international famous brands and grades of antifreeze

#### 4.3.1 RAYWIN antifreeze brand and model information

Table 3-5

Brand	Model	Spec.	Freezing Point	Available min. ambient temperature (°C)
HANHU	YCF4—8	4kg	-8°C	2
	YCF4—25		-25°C	-15
	YCF4—30		-30°C	-20

YCF4—35		-35°C	-25
YCF4—40		-40°C	-30
YCF4—45		-45°C	-35
YCF9—8	9kg	-8°C	2
YCF9—25		-25°C	-15
YCF9—30		-30°C	-20
YCF9—35		-35°C	-25
YCF9—40		-40°C	-30
YCF9—45		-45°C	-35
YCF10—8	10kg	-8°C	2
YCF10—25		-25°C	-15
YCF10—30		-30°C	-20
YCF10—35		-35°C	-25
YCF10—40		-40°C	-30
YCF10—45		-45°C	-35
YCF18—8	18kg	-8°C	2
YCF18—25		-25°C	-15
YCF18—30		-30°C	-20
YCF18—35		-35°C	-25
YCF18—40		-40°C	-30
YCF18—45		-45°C	-35
YCF200—8	200kg	-8°C	2
YCF200—25		-25°C	-15
YCF200—30		-30°C	-20
YCF200—35		-35°C	-25
YCF200—40		-40°C	-30
YCF200—45		-45°C	-35

Usually, choose the freezing point as 10°C lower than the lowest temperature of the equipment running area. For example: Suppose the minimum temperature in some area is -15 °C, then select antifreeze with type of -25.

#### 4.3.2 Note for using antifreeze

a) Please clean the engine cooling system with water before antifreeze is filled, it's better to clean it with demineralized or deionized water.

b) Pay attention to checking the antifreeze level and the tightness of cooling system. Do not fill up antifreeze fully if the machinery has no overflow tank, but 95% volume or so; If there is an overflow tank on the machinery, fill antifreeze to the specified scale firstly, then run the engine for a few minutes, and continue to fill antifreeze to the required scale;

c) The antifreeze from different manufacturers or with different types cannot be mixed, or else the antifreeze performance would be reduced, even it causes engine damage.

d) If the level is below required scale, please fill to a required scale. The filled antifreeze must be same type from same manufacturers as the existing antifreeze in the

engine.

e) The glycol is toxic, please clean it with water immediately if the glycol is contacted with skin; Glycol will burn in case of fire, so do not weld or make fire near the engine with antifreeze leakage; The boiling point of glycol is 197.4 °C, so it's easy to evaporate for the water in antifreeze, please make up water after the antifreeze works for some time.

#### 4.3.3 Replace antifreeze regularly.

- a) Light duty antifreeze/inorganic antifreeze replacement cycle is 24 months.
- b) Heavy duty antifreeze/organic antifreeze, replacement cycle is 36 months.
- c) The technical requirements of light duty antifreeze/inorganic antifreeze or heavy duty antifreeze/organic antifreeze should meet the petrochemical industry standards or RAYWIN Q /YC 908 "engine coolant technical conditions" requirement.

### 4.4 Battery selection

With the machinery electricity consumption is increasing in plateau or alpine regions in the winter (-15 °C or less), to ensure and improve engine cold starting performance, the machinery should be equipped with same capacity low temperature batteries.

**Table 3-6 Battery Selection Table**

Common region		Plateau or alpine region	
Battery capacity(Ah)	Cold starting current (A)	Battery capacity(Ah)	Cold starting current (A)
≥120 (165)	570	≥180 (195)	622
<b>Note</b>	It's better to select the battery type in the brackets for the engine that runs in plateau region.		

## 5. Engine Operation & Maintenance

### 5.1 Engine Operation

#### 5.1.1 Before starting

a) Check the oil level in the oil sump. The level should be within the upper and lower scale limits of the oil dipstick. If the oil volume is not enough, fill some oil as required after checking the accordance of oil grade with temperature.

b) Check the coolant level, add some coolant if necessary, and the accordance of coolant type with temperature should be checked before filling.

c) Check and exhaust the air in the fuel pipeline, and drain the water from the fuel filter.

d) Check the fuel tank. If the fuel is insufficient, refuel it after checking the accordance of fuel grade with temperature.

e) Check the electrical system (including connecting wires, switches, electrolyte, fill enough electrolyte if it's insufficient.)

f) Check the tension of the driving belt, the tension should be moderate as required.

### 5.1.2 Start



**Warning**

**Do not start the engine in the environment where may be flammable gases, that could be drawn into the engine through the intake system, resulting in engine acceleration and over-speed, which could cause fire, explosion and property damage. Engine manufacturer can't know how the user operates the engine. Engine user and operator are fully responsible for operating the engine safely under harsh environments.**



**Attention**

**The engine cannot be started unless the preparations have been completed and confirmed to comply with requirements. (The engine could be started after warmed in cold winter). The continuous starting time can't be over 10 seconds, the next starting time interval is should not be less than 1 minute, if it can't be started after three times trial in succession, user should check the reasons and restart it after the malfunction is removed.**



**Attention**

**Check the oil pressure: it should not be lower than 0.1MPa at idle speed. If the low oil pressure indicator still flash within 15 seconds or the oil gauge displays no oil pressure, please shut down the engine immediately to prevent engine from damage.**

Check whether the water pump operates properly and whether the coolant runs into water jacket of the diesel engine. Check the leakage of oil, fuel and water, and shoot the trouble if there is leakage. Check if there is abnormal noise. Check and confirm all meters work well. Please stop the engine immediately and check the reason if there is abnormal status, and send the engine to service center if necessary.

**Cold start:** Under the cold environment, it's the same as conventional starting operations. If there is preheating during start, please start the engine after the preheating indicator is turned off or flashing.

Starting steps after long time no running or oil replacement

To start the engine as per the normal steps stated in this chapter. The engine could

not be started if the ECU detects that the oil pressure does not meet the minimum pressure of motor starting value. It will take a longer time to start the engine if it is no running for a long time or with replacement of oil.

### 5.1.3 Running

When the diesel engine is started, it should keep running at low and medium revolution speed in sequence with no load, the engine could not run at high speed with full load unless the coolant temperature is higher than 60°C and oil temperature higher than 45°C. Pay attention to the following instructions:



#### Attention

**Do not idle for long time, or else it may reduce engine performance. The oil pressure should be not less than 0.1MPa**

Observe the meters reading frequently during engine operation, ensure the oil pressure, oil temperature and water temperature to be in normal range.

If there is alarm from meter, or engine abnormal sound or abnormal vibration, please stop the engine and check it as soon as possible.

Pay attention to the sealing of every water passage and the fuel pipe. If there is leakage, remedy it immediately.



#### Attention

**The new engine or overhauled engine is not allowed running at high-speed or with heavy load. In order to ensure a good break-in, the load should not exceed 65% within the first 40 hours.**

### 5.1.4 Stopping the diesel engine

Do not stop the engine sharply unless there is an emergency. Keeps the engine running at low revolution speed for 3 to 5 minutes before stopping it in order to make the engine cool down, and keep idling for 2 to 3 minutes in order that the oil could be carried to each part of the engine, then stop the diesel engine.

When the ambient temperature is below 5°C and the coolant is not sure to be anti-freezing, discharge all of the coolant liquid after stopping the engine to avoid engine damage by frost crack.

When the temperature is below -30 °C, the battery should be disassembled and moved to warm space, otherwise it would be hard to start the engine.

### 5.1.5 Routine Operating Notes:

Comparing to the traditional mechanic fuel system, electric control fuel pump requires higher fuel cleanliness.

Please fill cleaning fuel with regular stations.

Do not make the filled fuel contaminated.

When the fuel pipeline needs to be removed, the tools and hands must be cleaning to avoid the pipeline to be contaminated.

The malfunction indicator is on the control panel, if there is no malfunction, the indicator shall flash once then be turned off while the engine is electrified. If there is

malfunction, the indicator will be turned on automatically and the malfunction reminder will be displayed, please turn off the ignition switch, and check the engine fuel pipeline, air system and electric circuit carefully to find whether there is obvious fuel leakage, air leakage or connectors fallen off.

In principle, when the malfunction indicator is turned on, the user check and find there is obvious fuel pipeline, air system or electric circuit malfunction, the user may solve it by himself.

#### **5.1.6 Refilling method after the fuel consumed up.**

If there is air in the fuel pipeline when the fuel is consumed up or the fuel filter/fuel pipeline needs to be replaced, it must evacuate all air from the fuel pipeline as follows:

Release the air discharging screw on the top of fuel filter, deaerate the air with hand priming pump till the fuel filter is full of fuel, and tighten the air discharging screw after there is no any air bubble arising from the fuel.

Release the fuel return pipe from fuel pump, deaerate the air with hand priming pump till the fuel pump is full of fuel, and tighten the air discharging screw after there is no any air bubble arising from the fuel.

Release the connectors between fuel pipe and fuel injector for each cylinder, deaerate the air from fuel pipes by hand priming pump, and tighten the connectors till the fuel comes out from the pipes.

Wipe off all fuel on the surface of engine or surroundings after deaerating all air.

Avoid the fuel spilled on the exhaust pipe, starter, wiring harness (especially connectors) during deaerating, please wipe off the fuel that's spilled on the parts if any.

Ensure fuel cleaning from contamination during deaerating.

## **5.2 Maintenance of diesel engine**

- The initial maintenance should be made and recorded according to the warranty manual.
- During the use of diesel engines, the following requirements should also be carried out for routine maintenance, daily maintenance by the user own, other levels of maintenance by professional maintenance person;
  - Air filter is a key component to ensure the diesel engine clean air inhaled, to always check the air intake system and maintenance, to replace the air filter, ensure that the diesel engine does not appear early wear.

### **5.2.1 Diesel engine breaking-in**

The new diesel engine need to have breaking-in period (starting 50h), in order to make

the match performance of each moving parts to further improve, ensure the working reliability and service life of the diesel engine:

- 1) After starting the diesel engine in low speed to warm up for at least 5 minutes;
- 2) After starting, the load cannot be increased sharply, it needs to slowly increase;
- 3) Diesel engine idle speed or full load running not more than 5 minutes;
- 4) Often observe the oil, water temperature meter, to ensure the normal working status of the diesel engine;

The overhauled diesel engine, also need to have breaking-in period (refer to new machine breaking-in), to ensure of the friction pairs matching effect. After the end of the breaking-in period oil should be replaced, and replace the oil filter element. No idle running, which resulting in early wear and tear.

### 5.2.2 Wet exhaust pipe (smoke water mixer)

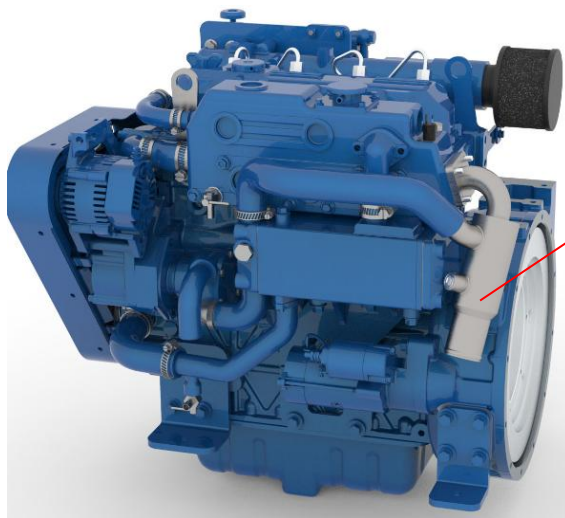

Smoke and water mixer (refer to the shape diagram of each model for the outer diameter of the interface)

### 5.2.3 Heat exchange system

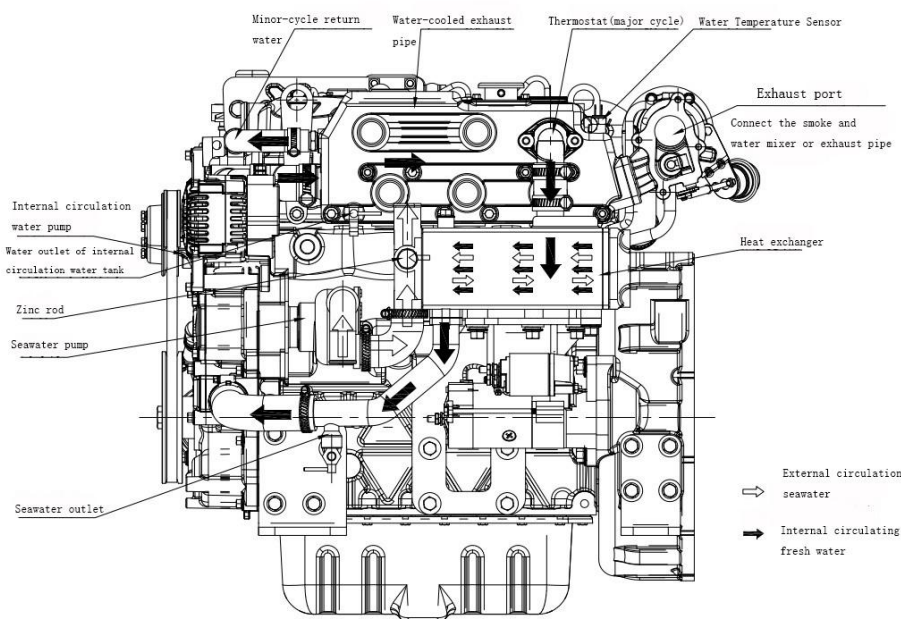

### 5.2.3.1 Heat exchanger

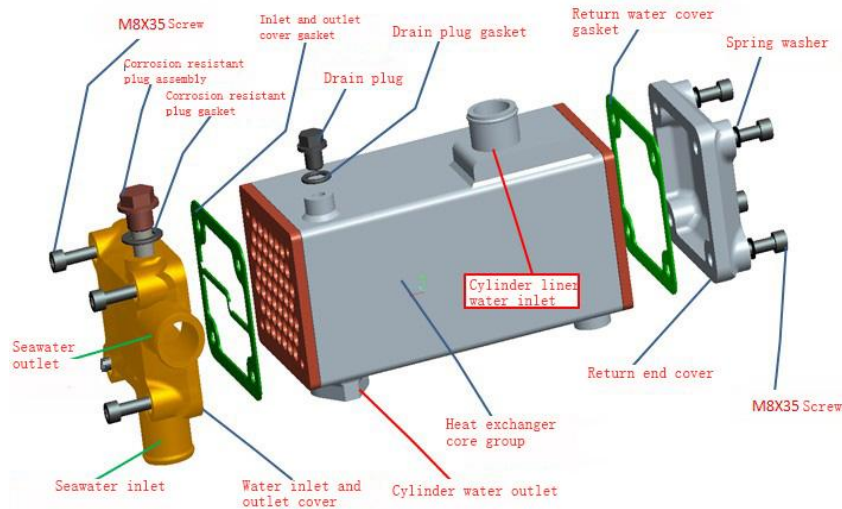

The core of the heat exchanger is a tubular structure. Seawater flows inside the pipe, while fresh water flows through the guide plate outside the pipe, exchanging heat through the cooling pipe to dissipate heat from the cylinder liner water. Zinc rods are installed on the end cover to slow down the corrosion of cooler components by seawater. After a period of use, a layer of scale will form on the surface of the zinc rod, which should be cleaned regularly, otherwise it will lose its anti-corrosion effect. After the zinc rod itself is corroded, it should be replaced with a new one.

1. Due to the corrosiveness of seawater, it can damage the surface of the protective layer, causing pipes to corrode and form dirt, reducing the flow area of seawater and reducing the cooling effect. Therefore, it should be cleaned regularly and frequently. Disassemble the inlet and outlet end covers of the heat exchanger, remove the cooling core, and immerse it in water containing detergent. Use a non-metallic brush to clean the inner diameter of the heat dissipation pipe. After removing the scale for 15 minutes, remove the water pipe bundle and thoroughly rinse it with water. Check the corrosion of the inlet and outlet end covers and zinc rods. All sealing rings/gaskets must be replaced.

2. It is recommended to replace the anti-corrosion zinc rod every 3 months.

## 5.2.4 Seawater pump

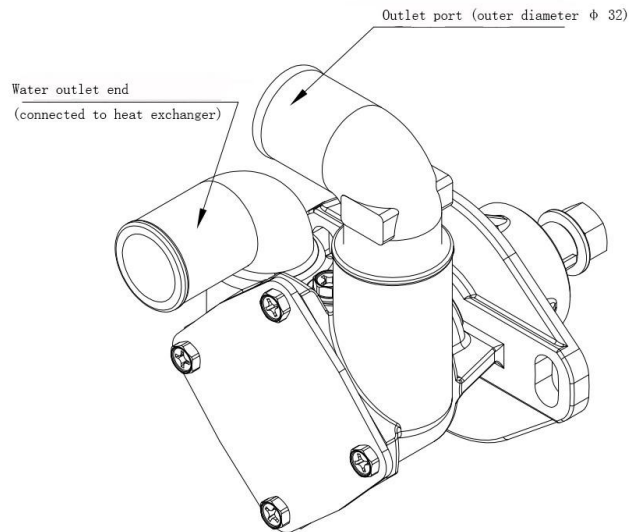

The seawater pump is equipped with a high flexibility plastic impeller. Please use and maintain the seawater pump correctly, otherwise it may cause a decrease in the pumping capacity or damage.

Maintenance precautions:

1. The seawater pump should not idle, otherwise it may cause severe impeller wear Loss;
2. Please install a seawater filtration device at the front end of the seawater pump inlet to prevent debris from entering the seawater pump, which may cause damage to the impeller of the water pump and damage to the water seal;
3. Regularly replace the impeller to ensure the pumping capacity of the seawater pump, otherwise it may cause poor engine cooling; When replacing the impeller, first remove the end cover, and then use tools to remove the rubber impeller. The impeller replacement cycle is 500 hours for inspection and 800 hours for replacement; When the engine is stopped for a long time, the seawater pump and pipeline should be drained of seawater, and compressed air should be used to blow dry any remaining water inside.

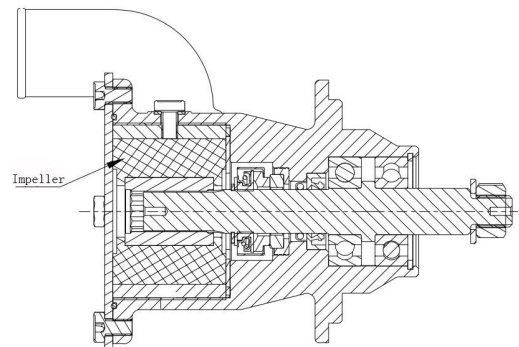

## 5.2.5 Maintenance of diesel engine

Correct, timely and careful maintenance can guarantee diesel engine working smoothly for a long time, to prevent the occurrence of fault, reduce wear, prolong the service life. The user should according to the content listed in diesel engine maintenance,

specific classification as follows:

**5.2.5.1 Maintenance cycle of the table below:**

Note: the use of harsh conditions (minimum temperatures below - 20°C, or the highest temperatures higher than 35°C, or environmental dust content in the high desert, mine site, construction sites, coal yards, etc.), it is necessary to shorten the replacement cycle of engine oil .

**List of 4D24 Series Engine Maintenance Intervals**

item	Maintenance intervals										
	50hrs	100hrs	250hrs	400hrs	500hrs	1 or 2 mouths	3 mouths	800hrs	1500hrs	3000hrs	2 years
Check the fuel line connections and drain the water from the diesel	☆										
※Oil change	★ first		☆								
Check position of battery electrolyte		☆									
Check fan belt tension and damage		☆									
Check radiator hose and hose clamp		☆									
※Change oil filter	★ first		☆								
Check the intake line			☆								
Change fuel filter			☆								
Clean core of air filter			☆								
Clean inner of fuel tank					☆						
Replace fan belt								☆			
Recharge battery		☆				☆					
Change core of air filter					☆						
Check valve clearance								☆			
※Check injector									☆		
Check turbocharger(if have)										☆	
Replace intake tube system											☆
Replace battery											☆
Replace radiator hose and hose clamp											☆
Replace fuel hose and clamp											☆
Replace radiator coolant(LLC)											☆
Inspecting the seawater pump impeller (marine)					☆						
Replacement of seawater pump impeller (marine)								☆			
Replacement of zinc rods (for boats)								☆			
Clean inside the water jacket and the											☆
Note: After running 50 hours, please change oil and oil filter											
According U.S. EPA off road emission standard, above items listed as the important items by our company											

## 6. Diesel engine daily maintenance instructions

Good maintenance from day to day of diesel engine and its system are beginning to understand, starting diesel engine before check the oil level and coolant level, check whether there is :

- ◆ leakage
- ◆ The loose and damaged parts
- ◆ The belt is worn or damaged
- ◆ Any change in the appearance of the diesel engine
- ◆ No fuel smell

At the same time need to see if there is no fault lights on, if there is a fault then need to identify, if it is historical failure, can be cleared .

This section describes the daily maintenance instructions of some of diesel engine system and parts.

### 6.1 Coolant level check of cooling system

Coolant level check



#### **Warning**

Do not open the radiator pressure cap from the hot diesel engine, should wait for coolant temperature below 50°C to open the pressure cap, otherwise high temperature coolant or steam spray may cause personal injury.



#### **Warning**

Coolant is poisonous to avoid contact with kids or pets. If it is not be used anymore, it should be treated according to the local environmental regulations.



#### **Warning**

Do not use corrosive cleaning agents in the cooling system, otherwise it will damage the aluminum parts.



#### **Attention**

Do not use the seal additive to solve the cooling system leakage problem. This will cause the cooling system block and the coolant flow is not smooth, thus causes the engine overheat.

The coolant level must be checked every day.



#### **Attention**

Do not add a cold coolant to the hot diesel engine, otherwise it will damage the Diesel Engine Castings, wait until the diesel engine temperature below 50 °C, then add coolant.

Adding coolant to the diesel engine must be mixed with the correct proportion of antifreeze, auxiliary coolant additives and water to prevent damage to the diesel engine.

Fill the coolant to the bottom of filler, of the radiator or expansion tank.

## 6.2 cooling fan

The user every day should visually inspect cooling fan. Check for cracks, loose rivets, curved blade or loose. Check the fan and ensure it is installed firmly. If necessary, tighten the bolt



### Warning

DO not rotate the diesel engine by pulling or prying fan. Otherwise it will damage the fan blade, resulting in fan fault and caused personal injury or property loss, should use accessory drive shaft and the crankshaft turning tool to rotate the crankshaft.



### Warning

Do not attempt to bend the blades of the fan or continue to use the damaged fan, bending or damaged fan blades cannot work properly, and will result in personal injury or property damage.◦

## 6.3 Fuel filter



### Warning

Discharge the water in the fuel filter (pre filter) to the container, and handle it in accordance with local environmental regulations.◦

RAYWIN required the user to install the fuel filter (pre filter and fine filter) or fuel-water separator, daily discharge water of fuel filter (pre filter) or water in oil-water separator and sediment in the fuel supply system ◦



### Attention

Close the discharge valve, the valve will not be overdone, excessive tightening will damage the thread.

## 6.4 Check oil level

User should check the oil level before each starting.



### Attention

It is strictly prohibited to running the engine in oil level below or above the oil limit marks, which can lead to diesel engine performance degradation and damage of diesel engine.

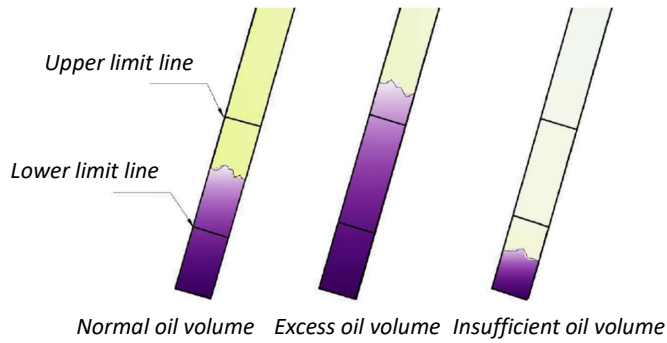

Fig. 5-1 Schematic diagram of oil dipstick

The precise reading can be measured after diesel engine shutdown. At least until diesel engine downtime longer than 15 minutes, then began to check the oil level. This period of time can let the oil back to the bottom of oil pan.



**Warning**

Used oil has a carcinogenic effect, and may produce reproductive disease, should avoid the inhalation of oil vapor, do not swallow and prolonged contact with the used oil, if no longer use should be handled in accordance with local environmental regulations



**Warning**

In order to reduce the possibility of personal injury, should avoid the skin direct contact with hot oil.

*Normal oil volume*

### 6.5 Drive belt check

*Normal oil volume*

Tightness of the belt cannot be too loose or too tight, too loose will reduce the transmission efficiency of the water pump, the rotation speed of the fan and the charger is not enough, influence the cooling effect. At the same time too-loose belt produces vibration will cause belt and pulley unnecessary wear, too tight, it will influence the belt and bearing parts service life.

### 6.6 Air filter

Users can observe the air resistance indicator to judge the air cleaner clogging which installed on the intake pipe of the air filter, when air resistance indicator changed from normal green to red, it indicates that the air intake filter resistance exceeds the limit value, and air filter need to be cleaned or replaced.



Fig.5-2 Air Filter

## Attention

The engine is absolutely forbidden to work in case of air filter failure or without air filter. The intake air must be pre-filtered to prevent dust and impurities, otherwise caused engine early damage.

### 6.7 Valve

In order to ensure the normal working status of diesel engine, the user should regularly check and adjust the valve clearance. In the cold status, the clearance of the intake valve is  $0.2 \pm 0.05 \text{mm}$ , the clearance of the exhaust valve is  $0.2 \pm 0.05 \text{mm}$

Valve clearance checking and adjustment method is:

The crankshaft turns to the first cylinder compression top dead point position, then you can check and adjust the 1,2,3,6 valve, after then the crankshaft rotates 360 degrees, then you can check and adjust the 4,5,7,8 valve. Valve clearance adjustment can be carried out by adjusting valve and adjusting screw. First loose lock nut, screw in or out with screwdriver, then check the rocker arm and the valve clearance with feeler, and tighten the lock nut after meeting the requirements.

## 7. Common trouble of diesel engine and removal methods

Note: This manual describes some typical engine operation problems, the reasons and the solutions.



### Warning

Implementation of this chapter of the fault diagnosis and elimination steps may result in machinery damage or personal injury or even death. It must be by trained technicians implement fault diagnosis and troubleshooting work. For not listed in this chapter the diagnosis and exclude steps and symptoms, please contact Raywin.

To make a fault diagnosis, please follow the following recommendations:

- ※Careful analysis of the problem before action;
- ※Start with the most easy and obvious place;
- ※Find the root causes and eliminate the problem.

In order to find fault in time, protect the diesel engine, greatly shorten the maintenance time, improve the utilization efficiency of the diesel engine, RAYWIN 4D24/B, 4D24T/B engine's ECU is with fault diagnosis function. ECU can make diagnose judgment by analyzing electric signals, to diagnose the most electronic components and a few mechanical component failures. Once the fault of electronic control system is detected by ECU, it will produce a corresponding fault code and save the information into ECU memory.

#### (Stanadyne pump no such steps)

I. Fault indicator

- These fault indicator is located on the dashboard ;
- These are generally red color (for more details please refer to machinery manual);
- These are self-checking after electricity, fault indicator light turns off after 2

seconds ;

- Light turns on once the failure of electrical failure system appears;
- General fault, fault indicator lighting;
- Serious faults, fault indicator flashing;
- Fault disappears, the malfunction indicator light off automatically.

## II. fault flash code reading method

Read fault flash code method through fault indicator lamp:

- These are the ignition switch in the ON place;
- with or without load;
- Press diagnose button to activate the fault diagnosis flash code;
- Each operation gets one fault flash code, all fault flash codes can be got one by one;
- Fault flash codes include current and historical code;
- Reading the code after cleaning, which is the current fault code.

For example, using the above method to read ECU memory warning lamp line fault, fault flash code 553, the flashing way of the fault indicator light is as follows:

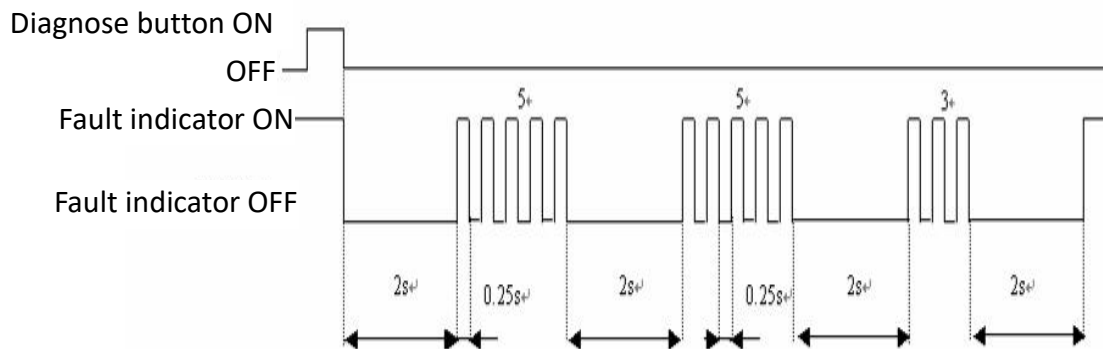

Fault code flash schematic diagram

## III. the method of cleaning the historical fault code

In practical application, it can remove the historical fault code in ECU memory conveniently and quickly by using diagnose button, the detail is as follows. :

- Press diagnosis request button;
  - Put the ignition button to the OFF place for more than 18 seconds, until ECU power off;
  - Put the ignition button to the ON place, ECU power on;
- ECU power on for 6 seconds (4~8 seconds), then release of the diagnosis request button.

## 7.1 Diesel engine cannot start

### failure cause

Fuel quality does not meet the requirements:

- 1、 Use incorrect grade of fuel;
- 2、 Excessive fuel impurities;
- 3、 Excessive water in fuel;

**Qualified to go to step one  
(Stanadyne pump no such steps)**

Electronic control system cannot power on

**Qualified to go to step two**

Battery voltage deficiency

**Qualified to go to step three**

The starter does not work

**Qualified to go to step four  
(Stanadyne pump no such steps)**

ECU memory has the fault code:

### Trouble shooting

Replace by qualified fuel, and clean fuel circuit.

Check wiring harness and fuse, main power switch, especially ignition switch.

Method for quickly judging fault :

1. Fault indicator light does not light when the power on self-test;
2. The diagnostic instrument cannot be connected;
3. The power line in the throttle connector cannot be 5V voltage

Replace battery or charge.

1. check the switches and wiring is intact, try to use emergency start (continued to press the switch-on request button for more than 5 seconds) to observe starter action.

2. check the start request button, start control relay and its circuit .

3. check whether the shutdown button is in the off status.

4. Check the starter.

1、 Check and repair the relevant parts or systems according to the fault

1、 The fault code can be read through the diagnostic instrument.

2、 The fault flash code can be read by the diagnosis request button.

The fault information of the electric control system can be read through the CAN meter。

code or the fault flash code information, if the fault information from crankshaft/camshaft, then jump to step four.

2、 After maintenance, use diagnostic instrument or diagnosis request button to delete the historical fault information, and run diesel engine fully, to confirm the ECU memory without fault code information。

**Qualified to go to step five (Stanadyne pump no such steps)**

Unable to set up work schedule:

1、 During the starting, the diagnostic instrument cannot monitor the speed changing;

2、 All crankshaft signals are lost

3、 Oscilloscope displays timing installation phase error ;

.....

1 Check if the crankshaft signal sensor is in good condition;

2 Check if crankshaft connector and the conducting wire is intact;

3 Check whether the crankshaft signal disc is damaged or not / dirty attachment (through the sensor signal hole)

4 Check the gap between crankshaft signal sensor and signal disk installation (generally 1 + 0.5mm);

5 If disassemble the signal plate and other components during maintenance, check if the timing phase assembly is correct 。

**Qualified to go to step six**

Low pressure fuel circuit failure

.....

1、 Make sure there is enough diesel in the tank;

2、 Elimination of air in low pressure fuel circuit;

3 、 Check the pipes, the joint tightening condition , and , whether the hose and the joint are affected by extrusion, damage, or the diameter is not correct;

4 、 Check whether the fuel filter, pre-filter are blocked or damaged;

5 、 Check whether the fuel tank ventilation device is blocked or contaminated (open tank cover and check pumping sound);

6、 Check whether the fuel pump and the inlet & outlet of filter are connected incorrectly。  
7、 Check whether transfer pump is failure。

**Qualified to go to step seven**

Injector fault

.....

1、 Check injector atomizing ;  
2、 Check injector shim thickness correct or not;  
3、 Check injector protrusion height correct or not 。

**Qualified to go to step eight**

High-pressure fuel pump failure:  
1、 Fuel channel blocked in high-pressure fuel pump;  
2、 High- pressure fuel pump plunger wear;  
3、 Relief valve of high-pressure pump blocked, contaminated or stuck。

.....

Clean or replace the high-pressure pump, replacement of clean fuel, full road test。

**Qualified to go to step nine**

Cylinder air tightness and compression performance failure:  
1、 Insufficient compression pressure;  
2、 Excessive wear of piston ring;  
3、 valve leakage。

.....

1、 Replace the piston ring, or machining the cylinder hole if necessary;  
2、 Check sealing of valve clearance, valve spring, valve guide and valve seat, grinding valve seat if sealing is not good;  
3、 Screw down, clean or replace;  
4、 Removal of combustion chamber carbon deposition;  
5、 Check if the crankshaft, connecting rod bending etc.。

**Qualified to go to step ten**

Other mechanical components failure

.....

1. Inspect fuel system/oil system;  
2. Inspect intake/exhaust system;  
3. Check if the filter is blocked, etc.。

## 7.2 Hard to start

### failure cause

Insufficient preheat:  
 1. Under cold conditions, starting before the cold start indicator light flashes off;  
 2. The battery voltage fluctuation is not normal in the pre heating process showed on the multimeter or the diagnostic instrument

.....

**Qualified to go to step one.**

Other reasons

.....

### Trouble shooting

1. Check whether the preheat circuit wiring is good;  
 2. Check whether the battery capacity is sufficient

Reference non-start troubleshooting process

## 7.3 Diesel engine insufficient power

### Failure course

Fuel quality does not meet the requirements:  
 1、 Use incorrect grade of fuel;  
 2、 Excessive fuel impurities;  
 3、 Excessive water in fuel;

.....

**Qualified to go to step one**  
 ( Stanadyne pump no such steps )

Fault code in ECU memory:  
 1 、 Fault codes can be read through the diagnostic instrument  
 2、 Fault flash codes can be read through diagnostic request button  
 3、 Electronic control system fault information can be read through CAN meter

.....

### Trouble shooting

Replace by qualified fuel, and clean fuel circuit.

1、 If the fault code or fault flash code information clearly points to a specific electronic control components, inspect and repair the corresponding faults of sensors , actuators and its line;  
 2 、 After repairs, use the diagnostic instrument or diagnostic request button to delete the fault historical information, and fully running engine to confirm ECU memory without fault code information.

**Qualified to go to step two**

Water temperature sensor

.....

- 1 、 Check the temperature sensor connector and circuit;
- 2 、 Check if the temperature sensor dirty or damaged;

**Qualified to go to step three**

Low pressure fuel circuit failure

.....

- 1、 Make sure there is enough diesel in the tank;
- 2、 Discharge of air in low pressure fuel circuit;
- 3、 Check the pipes, the joint tightening condition, and , whether the hose and the joint are affected by extrusion, damage, or the diameter is not correct;
- 4 、 Check whether the fuel filter, pre-filter are blocked or damaged;
- 5 、 Check whether the fuel tank ventilation device is blocked or contaminated (open tank cover and check pumping sound);
- 6、 Check whether the fuel pump and the inlet & outlet of filter are connected incorrectly.。
- 7 、 Check whether transfer pump is failure.。

**Qualified to go to step four**

Intake system block or leakage

.....

Check air filter, air inlet pipe, clean or replace air filter element 。

**Qualified to go to step five**

Exhaust back pressure is too high

.....

Check valve timing and adjust if necessary.。

**Qualified to go to step six**

Turbo system Failure

.....

- 1、 Check and eliminate the leakage from the pipe and connection;
- 2、 Turn the turbocharger shaft to confirm whether turbocharger shaft block or loosen;

3、 Check if turbocharger compressor impeller and turbine damaged.

**Qualified to go to step seven**

Fuel pipeline leakage or block

.....

Check the sealing condition of the fuel pipe and the joint, the blockage of the fuel filter, replace the pre-filter element or fuel filter element when necessary.

**Qualified to go to step eight**

Diesel engine coolant temperature is too high

.....

Check and repair radiator, thermostat, fan belt tension adjustment .

**Qualified to go to step nine**

Injector fault

.....

1、 Check injector atomizing ;  
2 、 Check injector shim thickness correct or not;  
3、 Check injector protrusion height correct or not .

**Qualified to go to step ten**

High-pressure fuel pump failure:  
1 、 Fuel channel blocked in high-pressure fuel pump;  
2 、 High- pressure fuel pump plunger wear;  
3、 Relief valve of high-pressure pump blocked, contaminated or stuck.

.....

Clean or replace the high-pressure pump, replacement of clean fuel, full road test.

**Qualified to go to step eleven**

Cylinder air tightness and compression performance failure:  
1 、 Insufficient compression pressure;  
2 、 Excessive wear of piston ring;  
3、 valve leakage.

.....

1 、 Replace the piston ring, or machining the cylinder hole if necessary;  
2、 Check sealing of valve clearance, valve spring, valve guide and valve seat, grinding valve seat if sealing is not good;  
3、 Screw down, clean or replace;  
4 、 Removal of combustion chamber carbon deposition;  
5、 Check if the crankshaft, connecting rod bending etc.。

**Qualified to go to step twelve  
(Stanadyne pump no such steps)**

The control function of the other control module on CAN network and the control function of the diesel engine ECU are interfered

Alternately disconnect other control modules on the CAN network until the communication or function is restored

**Qualified to go to step thirteen**

Additional power consumption is too large

.....

Check whether the working cycle time of the cooling fan and the driving device of the diesel engine are working normally.

**Qualified to go to step fourteen**

Internal damage of diesel engine

.....

Check and replace damaged parts at the service station

**7.4 Abnormal sound during running**

Quickly eliminating faults by positioning fault place according to the abnormal sound location. Distinguishing the sound from rotating parts, variation interfered and resonance. Sound of the rotating parts is usually regular, and resonant sound will disappear or strengthen according to speed change.

Failure cause (Stanadyne pump no such steps)

Fault code in ECU memory:  
1、 Fault codes can be read through the diagnostic instrument  
2、 Fault flash codes can be read through diagnostic request button  
3、 Electronic control system fault information can be read through CAN meter

.....

Trouble shooting

1、 If the fault code or fault flash code information clearly points to a specific electronic control components, inspect and repair the corresponding faults of sensors , actuators and its line;  
2、 After repairs, use the diagnostic instrument or diagnostic request button to delete the fault history information, and fully running engine to confirm ECU memory without fault code information.

**Qualified to go to step one**

Crankshaft sensor and its circuit fault

.....

1、 Check crankshaft sensor connector and circuit;  
2、 Check whether installation clearance between crankshaft sensor and the signal panel is installed

correctly;  
3、 Check whether the crankshaft sensor is dirt or damage。

**Qualified to go to step two**

Idle speed abnormal sound

.....

1、 Check if there is air in fuel pipes;  
2、 Check whether injector is normal or not ;  
3、 Fuel filter has a stagnant water cause insufficient fuel supply.

**Qualified to go to step three**

Abnormal sound during acceleration

.....

1、 Check whether air filter is clean, or blocked. Replace the air filter if necessary.  
2、 Check whether intake and exhaust pipes connected well or leak, air leakage need to be solved.  
3、 Check whether turbocharger connection pipes are fastened, cleaned, sealed well, or cracked, clean or replace if necessary.  
4、 Turbocharger bearing broken, rotating parts and housing collide with each other.;  
Turbocharger surge due to too high altitude。

**Qualified to go to step four**

Mechanical noise / Abnormal sound during acceleration

.....

1、 Check timing mark.  
2、 Check whether the valve timing and valve clearance is correct, adjust if necessary.  
3、 Check whether the valve spring is abnormal, replace if necessary.  
4、 Serious wear of camshaft or rocker shaft .  
5、 Confirm the sealing of cylinder gasket, replace if necessary.  
6、 Confirm whether the breather and piston ring are working properly, replace if necessary.  
7、 Piston clearance is too large;  
8、 Timing mechanism worn。

## 7.5 Exhaust smoke

Machinery without special engine for plateau works overload on the plateau , it will exhaust black smoke, which is normal phenomenon, and the black smoke will disappear if machinery leaves plateau.

failure cause	Trouble shooting
<p>Fuel quality does not meet the requirements:</p> <ol style="list-style-type: none"> <li>1、 Use incorrect grade of fuel;</li> <li>2、 Excessive fuel impurities;</li> <li>3、 Excessive water in fuel;</li> </ol>	<p>Replace by qualified fuel, and clean fuel circuit。</p>
.....	
<p><b>Qualified to go to step one (Stanadyne fuel pump has no such steps)</b></p> <p>Fault code in ECU memory:</p> <ol style="list-style-type: none"> <li>1 、 Fault codes can be read through the diagnostic apparatus</li> <li>2、 Fault flash codes can be read through diagnostic request switch</li> <li>3、 Electronic control system fault information can be read through CAN meter</li> </ol>	<ol style="list-style-type: none"> <li>1、 If the fault code or fault flash code information clearly points to a specific electronic control components, inspect and repair the corresponding faults of sensors , actuators and its line;</li> <li>2、 If read fuel volume slip ring control model related fault codes or fault flash codes information, focus on investigation fuel related failures according to the subsequent steps</li> <li>3 、 After repairs, use the diagnostic apparatus or diagnostic request switch to delete the fault history information, and fully running engine to confirm ECU memory without fault code information.</li> </ol>
.....	
<p><b>Qualified to go to step two</b></p> <p>Cooling water temperature sensor or circuit fault</p>	<p>Check the cooling water temperature sensor and its circuit, through the diagnostic instrument monitoring the temperature signal value to see if lower than the actual value; dismantle the coolant temperature sensor connector if necessary, and start engine to compare</p>
.....	

<b>Qualified to go to step three</b>	
The resistance of air intake system exceeds technical requirement	..... Check if the intake system is blocked. If necessary, clean or replace the air filter and the intake manifold.
<b>Qualified to go to step four</b>	
Intake or exhaust leakage	..... Check whether the air intake system and the exhaust system leak air .
<b>Qualified to go to step five</b>	
Blockage or leakage of radiator	..... Check if the radiator is blocked or leaked.
<b>Qualified to go to step six</b>	
Exhaust system resistance exceeds technical requirement	..... Check if the exhaust system is blocked.
<b>Qualified to go to step seven</b>	
Muffler extrusion deformation or blockage	..... Replace muffler
<b>Qualified to go to step eight</b>	
Injector fault	..... 1、 Check injector atomizing ; 2 、 Check injector shim thickness correct or not; 3 、 Check injector protrusion height correct or not 。
<b>Qualified to go to step nine</b>	
Valve leakage or valve clearance abnormal	..... Check and adjust the valve seal and valve clearance
<b>Qualified to go to step ten</b>	
Insufficient pressure of the turbo system	..... Check and solve the leakage from the pipe and connection.
<b>Qualified to go to step eleven</b>	
Turbocharger operation disorder	..... The turbocharger cannot be rotated or stuck, check and replace turbocharger
<b>Qualified to go to step twelve</b>	
Power consumption is too large	..... Check whether the working cycle time of the cooling fan and the driving device of the diesel engine are working normally.
<b>Qualified to go to step thirteen</b>	
Internal damage of diesel engine	..... Check and replace damaged parts at the service station

## 7.6 White and blue smoke

White smoke appears sometimes when engine cold start, and water temperature is increased after running for a while, the white smoke will disappear, this is normal phenomenon, not a fault.

failure cause	Trouble shooting
<p>Fuel quality does not meet the requirements:</p> <ol style="list-style-type: none"> <li>1、 Use incorrect grade of fuel;</li> <li>2、 Excessive fuel impurities;</li> <li>3、 Excessive water in fuel;</li> </ol>	<p>Replace by qualified fuel, and clean fuel circuit.</p>
<p><b>Qualified to go to step one (Stanadyne fuel pump has no such steps)</b></p>	
<p>Fault code in ECU memory:</p> <ol style="list-style-type: none"> <li>1 、 Fault codes can be read through the diagnostic apparatus</li> <li>2、 Fault flash codes can be read through diagnostic request switch</li> <li>3、 Electronic control system fault information can be read through CAN meter</li> </ol>	<ol style="list-style-type: none"> <li>1、 If the fault code or fault flash code information clearly points to a specific electronic control components, inspect and repair the corresponding faults of sensors , actuators and its line;</li> <li>2 、 After repairs, use the diagnostic apparatus or diagnostic request switch to delete the fault history information, and fully running engine to confirm ECU memory without fault code information.</li> </ol>
<p><b>Qualified to go to step two</b></p>	
<p>Cooling water temperature sensor or circuit fault</p>	<p>Check the cooling water temperature sensor and its circuit, through the diagnostic instrument monitoring the temperature signal value to see if lower than the actual value; dismantle the coolant temperature sensor connector if necessary, and start engine to compare</p>
<p><b>Qualified to go to step three</b></p>	
<p>Diesel engines work at lower temperatures</p>	<p>Check the working temperature of the thermostat and replace it if necessary.</p>
<p><b>Qualified to go to step four</b></p>	

The temperature is too low to start the auxiliary preheat failure

.....

Check whether the preheating plug is able to work properly.

**Qualified to go to step five**

Low pressure fuel circuit failure

.....

- 1、 Make sure there is enough diesel in the tank;
- 2、 Elimination of air in low pressure fuel circuit;
- 3、 Check the pipes, the joint tightening condition, and , whether the hose and the joint are affected by extrusion, damage, or the diameter is not correct;
- 4、 Check whether the fuel filter, pre-filter are blocked or damaged;
- 5、 Check whether the fuel tank ventilation device is blocked or contaminated (open tank cover and check pumping sound);
- 6、 Check whether the fuel pump and the inlet & outlet of filter are connected incorrectly.。
- 7、 Check whether transfer pump is failure.。

**Qualified to go to step six**

Air filter clogging resulted in an increase in the cylinder intake resistance and poor intake, forming a certain negative pressure, the lubricating oil is absorbed into the combustion chamber

.....

Check whether the air filter is blocked 。

**Qualified to go to step seven**

Oil level of oil pan is too high

.....

Check whether the oil level of oil pan exceeds the upper limit or not.

**Qualified to go to step eight**

Turbocharger seal ring worn

.....

Check and replace 。

**Qualified to go to step nine**

Turbocharger thrust bearing worn

.....

Check and replace

**Qualified to go to step ten**

Turbocharger oil return line block

.....

Clean, repair

**Qualified to go to step eleven**

Injector fault

.....

1、 Check injector atomizing ;  
2 、 Check injector shim thickness correct or not;  
3 、 Check injector protrusion height correct or not 。

**Qualified to go to step twelve**

Valve leakage or abnormal lash

.....

Check and adjust the valve seal and valve clearance 。

**Qualified to go to step thirteen**

Coolant leaking into the combustion chamber

Check the coolant leaks 。

**Qualified to go to step fourteen**

Cylinder wall, piston and piston ring wear serious, too large clearance, cause oil sneaked into the combustion chamber and burn

.....

Check condition of cylinder wall, piston and piston ring 。

**Qualified to go to step fifteen**

Clearance between valve and guide is too large , oil is sucked into the combustion chamber

.....

Replace worn valve and valve guide.

**Qualified to go to step sixteen**

Compression pressure is low, the combustion is not complete

.....

Check the piston ring and cylinder gasket.

**Qualified to go to step seventeen**

Piston ring installation in the wrong direction , openings have not staggered

.....

Check and re-assembly 。

**Qualified to go to step eighteen**

Long-term low-load operation

.....

Pay attention to use appropriate operating speed and load.

**Qualified to go to step nineteen**

Internal damage of diesel engine

.....

Analysis of the oil and check the oil filter, identify possible damaged parts

## 7.7 Oil pressure anomaly

### 6.7.1 Low oil pressure

**Failure cause (Stanadyne fuel pump has no such steps)**

Fault code in ECU memory:

- 1、 Fault codes can be read through the diagnostic apparatus
- 2、 Fault flash codes can be read through diagnostic request switch
- 3、 Electronic control system fault information can be read through CAN meter

**Qualified to go to step one**

Oil temperature gauge , oil pressure sensor or oil temperature sensor failure, or installed wrong location

**Qualified to go to step two**

Lubricating oil thinning or improper use of lubricating oil

**Qualified to go to step three**

Oil filter regulator failure or improper adjustment

**Qualified to go to step four**

Oil filter clogging

**Qualified to go to step five**

Lubricating oil pump inlet pipe crack

**Qualified to go to step six**

Fixing bolts of inlet pipe of lubricating oil pump loose

**Qualified to go to step seven**

Rotor of lubricating oil pump

### Trouble shooting

1、 If the fault code or fault flash code information clearly points to a specific electronic control components, inspect and repair the corresponding faults of sensors , actuators and its line;

2、 After repairs, use the diagnostic apparatus or diagnostic request switch to delete the fault history information, and fully running engine to confirm ECU memory without fault code information.

Check whether the oil pressure gauge , oil pressure sensor , oil temperature sensor or their circuits work properly, and whether they are in the correct position.

Select appropriate lubricating oil according to provisions

Repair

Replace oil filter

Repair or replace。

Tighten to the specified torque。

Replace the oil pump。

wear or too large assembly clearance

**Qualified to go to step eight**

Bearing clearance is too large

.....

Check and replace

### 7.7.2 High oil pressure

**Failure cause (Stanadyne fuel pump has no such steps)**

### Trouble shooting

Fault code in ECU memory:  
1、 Fault codes can be read through the diagnostic apparatus  
2、 Fault flash codes can be read through diagnostic request switch  
3、 Electronic control system fault information can be read through CAN meter

1、 If the fault code or fault flash code information clearly points to a specific electronic control components, inspect and repair the corresponding faults of sensors , actuators and its line;  
2、 After repairs, use the diagnostic apparatus or diagnostic request switch to delete the fault history information, and fully running engine to confirm ECU memory without fault code information.

.....

**Qualified to go to step one**

Oil temperature gauge , oil pressure sensor or oil temperature sensor failure, or installed wrong location

Check whether the oil pressure gauge , oil pressure sensor , oil temperature sensor or their circuits work properly, and whether they are in the correct position.

.....

**Qualified to go to step two**

Temperature is too low, oil viscosity increases

Select specified grade lubricating oil , low speed running after start, inspection after oil temperature become normal.

.....

**Qualified to go to step three**

Relief valve blocked

Inspect and clean.

.....

## 7.8 High oil consumption

Failure cause	Trouble shooting
External lubricating oil pipeline leaks	Check and repair.
<b>Qualified to go to step one</b>	
Diesel engine overload	1、 Reducing the load。 2、 Confirm whether the intake system abnormality, diesel engine will cause overload if blocked.
<b>Qualified to go to step two</b>	
Improper use of lubricating oil	Choose according to regulations.
<b>Qualified to go to step three</b>	
Dipstick calibrates incorrectly	Check or replace dipstick.
<b>Qualified to go to step four</b>	
Breather blocked	Replace breather.
<b>Qualified to go to step five</b>	
Air filter blocked, oil sneak into turbocharger	Check whether the air filter is blocked, confirm the turbocharger shaft rotation is normal rotation without clamping.
<b>Qualified to go to step six</b>	
Piston ring jammed or wear too much	Check, repair and replace if necessary.
<b>Qualified to go to step seven</b>	
Cylinder hole worn too much	Holing and replace piston ring
<b>Qualified to go to step eight</b>	
Valve guide wear too much, valve stem seal failure	Check and replace.

## 7.9 Cooling water temperature too high (alarm)

Failure cause		Trouble shooting
Lack of cooling water, the water flow is inappropriate small	.....	Check whether the cooling water is adequate, add if insufficient
<b>Qualified to go to step one</b>		
Whether the belt is too loose	.....	Adjust
<b>Qualified to go to step two</b>		
The water temperature instrument damage, the water temperature induction plug failure	.....	Check whether the actual temperature is consistent with the temperature indicator; if not, replace the induction plug or water temperature instrument
<b>Qualified to go to step three</b>		
Expansion tank does not seal well	.....	Repair in time
<b>Qualified to go to step four</b>		
water pump leaks	.....	Repair in time
<b>Qualified to go to step five</b>		
Thermostat failure, damage	.....	Check and replace
<b>Qualified to go to step six</b>		
Punching cylinder gasket	.....	Check and replace
<b>Qualified to go to step seven</b>		
Matching problem between radiator and fan under modification condition	.....	Re-match on request

## 7.10 Common failure of turbocharger and its Trouble shooting

Failure cause		Trouble shooting
Intake System blocked	.....	Check the pipes between air filter and compressor, the compressor outlet, intake pipes, and intake manifold. Clean all.
<b>Qualified to go to step one</b>		
Intake leakage	.....	Check leakage of the pipes between air filter and compressor, the pipes between compressor outlet and inlet, connection between intake manifold and engine. Tighten bolts, replace gaskets and other parts if necessary
<b>Qualified to go to step two</b>		
Exhaust system blocked	.....	Repair or replace related parts
<b>Qualified to go to step three</b>		
Exhaust leakage	.....	Check connections of exhaust manifold and diesel engine, inlet of turbo and exhaust manifold, turbo housing and intermediate housing, turbo outlet and exhaust manifold, replace the gasket if leakage, tighten the bolts.
<b>Qualified to go to step four</b>		
Compressor rotor interference with compressor housing body or turbo housing	.....	Replace assembly.
<b>Qualified to go to step five</b>		
Inlet or return oil pipe leakage	.....	Replace.

## 7.11 Diesel engine self extinguishing

Failure cause		Trouble shooting
<p>Fuel quality does not meet the requirements:</p> <ol style="list-style-type: none"> <li>1、 Use incorrect grade of fuel;</li> <li>2、 Excessive fuel impurities;</li> <li>3、 Excessive water in fuel;</li> </ol>	<p>.....</p>	<p>Replace by qualified fuel, and clean fuel circuit.</p>
<p><b>Qualified to go to step one (Stanadyne fuel pump has no such steps)</b></p>		
<p>Fault code in ECU memory:</p> <ol style="list-style-type: none"> <li>1 、 Fault codes can be read through the diagnostic apparatus</li> <li>2、 Fault flash codes can be read through diagnostic request switch</li> <li>3、 Electronic control system fault information can be read through CAN meter</li> </ol>	<p>.....</p>	<ol style="list-style-type: none"> <li>1、 If the fault code or fault flash code information clearly points to a specific electronic control components, inspect and repair the corresponding faults of sensors , actuators and its line;</li> <li>2、 If read fuel volume slip ring control model related fault codes or fault flash codes information, focus on investigation fuel related failures according to the subsequent steps</li> <li>3 、 After repairs, use the diagnostic apparatus or diagnostic request switch to delete the fault history information, and fully running engine to confirm ECU memory without fault code information.</li> </ol>
<p><b>Qualified to go to step two</b></p>		
<p>Fuel running out</p>	<p>.....</p>	<p>Check, add, and remove the air from the fuel circuit.</p>
<p><b>Qualified to go to step three</b></p>		
<p>Ignition switch circuit failure</p>	<p>.....</p>	<p>Check the machinery ignition switch circuit</p>
<p><b>Qualified to go to step four (Stanadyne fuel pump has no such steps)</b></p>		
<p>Battery power supply to the ECU, voltage too low, interrupt or open circuit</p>	<p>.....</p>	<p>Check battery terminals, fuses and related circuits.。</p>

**Qualified to go to step five**

Crankshaft sensor and its circuit fault

.....

- 1、 Check crankshaft sensor connector and circuit;
- 2、 Check whether installation clearance between crankshaft sensor and the signal panel is installed correctly.;
- 3 、 Check whether the crankshaft sensor is dirt or damage。

**Qualified to go to step six**

Low pressure fuel circuit failure

.....

- 1、 Make sure there is enough diesel in the tank;
- 2、 Discharge of air in low pressure fuel circuit;
- 3、 Check the pipes, the joint tightening condition, and , whether the hose and the joint are affected by extrusion, damage, or the diameter is not correct;
- 4 、 Check whether the fuel filter, pre-filter are blocked or damaged;
- 5 、 Check whether the fuel tank ventilation device is blocked or contaminated (open tank cover and check pumping sound);
- 6、 Check whether the fuel pump and the inlet & outlet of filter are connected incorrectly.。
- 7 、 Check whether transfer pump is failure。

**Qualified to go to step seven**

Injector fault

.....

- 1、 Check injector atomizing ;
- 2 、 Check injector shim thickness correct or not;
- 3 、 Check injector protrusion height correct or not 。

**Qualified to go to step eight**

High-pressure fuel pump failure:  
1 、 Fuel channel blocked in high-pressure fuel pump;

.....

Clean or replace the high-pressure pump, replacement of clean fuel, full road test。

2、 High- pressure fuel pump plunger wear;  
3、 Relief valve of high-pressure pump blocked, contaminated or stuck。

**Qualified to go to step nine**

Diesel engine lubricating oil path is not smooth , cause bearing wear.

.....

If the water temperature is normal and engine sudden stop, Most of such case belong to this situation, should open the oil pan inspection, maintenance, replacement of damaged parts corresponding

**Qualified to go to step ten**

Diesel engine overheated and scuffing, generally due to water shortage or water temperature is too high

.....

Let the engine self-cooling (not allowed to fill the cold water or flush with cold water), and then try to rotate the crankshaft, if there is no stuck, can be added with cooling water and then start engine. If crankshaft cannot be rotated regular, engine should be disassembled, inspected, repaired, replaced damaged parts.

**Qualified to go to step eleven (Stanadyne fuel pump has no such steps)**

Diesel engine ECU failure

.....

Replace ECU。

**Qualified to go to step twelve**

Internal damage of diesel engine

.....

Check and replace damaged parts at the service station

## 7.12 Diesel engine vibration

### Failure cause (Stanadyne fuel pump has no such steps)

Fault code in ECU memory:

- 1、 Fault codes can be read through the diagnostic instrument
- 2、 Fault flash codes can be read through diagnostic request button
- 3、 Electronic control system fault information can be read through CAN meter

#### Qualified to go to step one

Ignition switch circuit failure

Qualified to go to step two  
**(Stanadyne fuel pump has no such steps)**

Battery power supply to the ECU, voltage abnormal or interrupt

#### Qualified to go to step three

Crankshaft sensor and its circuit fault

#### Qualified to go to step four

Low pressure fuel circuit failure

### Trouble shooting

1、 If the fault code or fault flash code information clearly points to a specific electronic control components, inspect and repair the corresponding faults of sensors , actuators and its line;

2、 After repairs, use the diagnostic instrument or diagnostic request button to delete the fault historical information, and fully running engine to confirm ECU memory without fault code information.

Check the machinery ignition switch circuit

Check whether the battery terminals and related circuits are not in contact

1、 Check crankshaft sensor connector and circuit;

2、 Check whether installation clearance between crankshaft sensor and the signal panel is installed correctly.;

3、 Check whether the crankshaft sensor is dirt or damage。

1、 Make sure there is enough diesel in the tank;

2、 Elimination of air in low pressure fuel circuit;

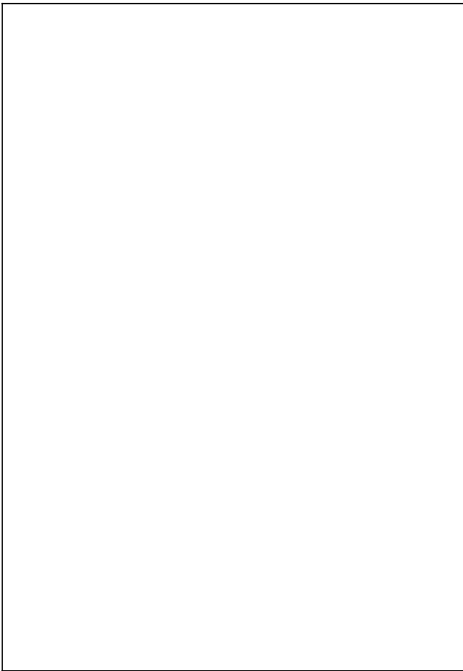

- 3、 Check the pipes, the joint tightening condition, and , whether the hose and the joint are affected by extrusion, damage, or the diameter is not correct;
- 4、 Check whether the fuel filter, pre-filter are blocked or damaged;
- 5、 Check whether the fuel tank ventilation device is blocked or contaminated (open tank cover and check pumping sound);
- 6、 Check whether the fuel pump and the inlet & outlet of filter are connected incorrectly.。
- 7、 Check whether transfer pump is failure.。

**Qualified to go to step five**

Injector fault

.....

- 1. Check injector atomizing ;
- 2. Check injector shim thickness correct or not;
- 3. Check injector protrusion height correct or not.

**Qualified to go to step six**

Pressure temperature sensor or circuit fault

.....

Check the pressure temperature sensor and its line on the intake manifold, and monitor the value of the intake pressure signal by the diagnostic instrument to see whether it is lower than the actual value.。

**Qualified to go to step seven**

Cooling water temperature sensor or circuit fault

.....

Check the cooling water temperature sensor and its circuit, through the diagnostic instrument monitoring the temperature signal value to see if lower than the actual value; dismantle the coolant temperature sensor connector if necessary, and start engine to compare

**Qualified to go to step eight**

Engine mounting bolts loose,

.....

Fastening bolts, replace shock pad,

shock pad damaged, the power transmission system is not align

realign.

**Qualified to go to step nine**

Intake system blockage or leakage

.....

Check whether the air filter or intake pipes is blocked or leaked

**Qualified to go to step ten**

Turbocharger damaged or surge

.....

Replace the turbocharger, check the working conditions and whether intake pipes are blocked

**Qualified to go to step eleven**

Accessories failure

.....

Check the fan, alternator, belt, bracket, whether interfere or damage, etc.

**Qualified to go to step twelve (Stanadyne fuel pump has no such steps)**

Diesel engine ECU failure

.....

Replace ECU.

**Qualified to go to step thirteen**

Internal damage of diesel engine

.....

Check and replace damaged parts at the service station

**7.13 Unstable idle speed of diesel engine**

**(Stanadyne fuel pump has no such steps)**

Fault code in ECU memory:  
1、 Fault codes can be read through the diagnostic instrument  
2、 Fault flash codes can be read through diagnostic request button  
3、 Electronic control system fault information can be read through CAN meter

.....

**Trouble Shooting**

1、 If the fault code or fault flash code information clearly points to a specific electronic control components, inspect and repair the corresponding faults of sensors , actuators and its line;  
2、 After repairs, use the diagnostic instrument or diagnostic request button to delete the fault history information, and fully running engine to confirm ECU memory without fault code information.

---

**Qualified to go to step one**

Crankshaft sensor and its circuit  
fault

.....

- 1、 Check crankshaft sensor connector and circuit;
- 2 、 Check whether installation clearance between crankshaft sensor and the signal panel is installed correctly.;
- 3 、 Check whether the crankshaft sensor is dirt or damage。

**Qualified to go to step two**

Low pressure fuel circuit failure

.....

- 1、 Make sure there is enough fuel in the tank;
- 2、 Elimination of air in low pressure fuel circuit;
- 3、 Check the pipes, the joint tightening condition , and , whether the hose and the joint are affected by extrusion, damage, or the diameter is not correct;
- 4、 Check whether the fuel filter, pre-filter are blocked or damaged;
- 5、 Check whether the fuel tank ventilation device is blocked or contaminated (open tank cover and check pumping sound);
- 6、 Check whether the fuel pump and the inlet & outlet of filter are connected incorrectly.。
- 7、 Check whether transfer pump is failure.。

**Qualified to go to step three**

Injector fault

.....

- 1、 Check injector atomizing ;
- 2、 Check injector shim thickness correct or not;
- 3、 Check injector protrusion height correct or not.

**Qualified to go to step four**

---

Shock pad damage	.....	Check shock pad.
<b>Qualified to go to step five (Stanadyne fuel pump has no such steps)</b>		
Vehicle speed sensor and its circuit fault	.....	Check vehicle speed sensor and its circuit.
<b>Qualified to go to step six</b>		
Intake system blockage or leakage	.....	Check whether the air filter or intake pipes is blocked or leaked
<b>Qualified to go to step seven</b>		
Valve leakage or abnormal lash	.....	Check and adjust the valve seal and valve clearance.
<b>Qualified to go to step eight (Stanadyne fuel pump has no such steps)</b>		
Diesel engine ECU failure	.....	Replace ECU.
<b>Qualified to go to step nine</b>		
Internal damage of diesel engine	.....	Analyze the oil and check the oil filter to determine the potential damage.

## 7.14 Oil dilution

Failure cause		Trouble shooting
Injector sealing problems	.....	1、 Injector mounting hole gland damage cause leakage; 2、 Injector leak in the cylinder head
<b>Qualified to go to step one</b>		
Cylinder head crack	.....	Replace
<b>Qualified to go to step two</b>		
Fuel pump seal not well.	.....	Replace fuel seal
<b>Qualified to go to step three</b>		
Injector O ring damaged	.....	Check the O ring.

## 7.15 System lamp / fault lamp is always light (Stanadyne fuel pump has

no such steps)

### Failure cause

Diagnostic request button is turned on

.....

### Trouble shooting

Disconnect the diagnostic request button

### Qualified to go to step two

Fault code in ECU memory:

- 1、 Fault codes can be read through the diagnostic instrument
- 2、 Fault flash codes can be read through diagnostic request button
- 3、 Electronic control system fault information can be read through CAN meter

.....

- 1、 If the fault code or fault flash code information clearly points to a specific electronic control components, inspect and repair the corresponding faults of sensors , actuators and its line;
- 2、 After repairs, use the diagnostic instrument or diagnostic request button to delete the fault history information, and fully running engine to confirm ECU memory without fault code information.

## **Raywin Powertrain Technology Co., Ltd**

**Add:NO.99jiujiang Rd,Shuangfu District,Jiangjin District,Chongqing,China**

**Tel: +86-23-85553153**

**Email: [info@raywin.cc](mailto:info@raywin.cc)**

**Website:<http://www.raywinpower.com>**